

Operator's Manual

CRAFTSMAN[®]

2.5 HP (Max. Developed)

10" Blade

4800 R.P.M.

COMPOUND MITER SAW

With Laser Trac[®]

Model 137.212140

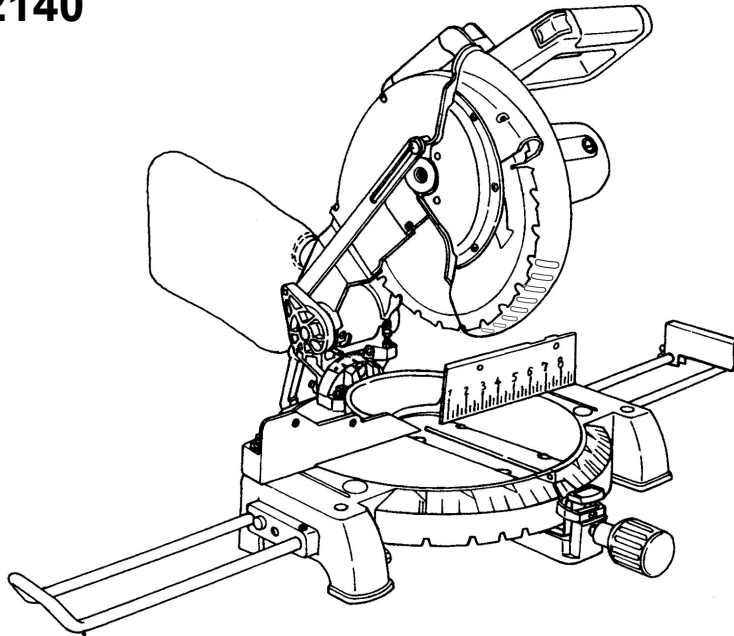

CAUTION:

Before using this Miter Saw, read this manual and follow all its Safety Rules and Operating Instructions

- Safety Instructions
- Installation
- Operation
- Maintenance
- Parts List

Customer Help Line
1-800-843-1682

Sears, Roebuck and Co., Hoffman Estates, IL 60179 U.S.A.

Visit our Craftsman website: www.sears.com/craftsman

Part No.:137212140001

TABLE OF CONTENTS

SECTION	PAGE	SECTION	PAGE
Warranty	2	Know Your Compound Miter Saw.....	8
Product Specifications	2	Glossary of Terms.....	9
Power Tool Safety	3	Assembly and Adjustments.....	10
Compound Miter Saw Safety.....	4	Operation.....	15
Electrical Requirements and Safety.....	4-5	Maintenance	22
Accessories and Attachments.....	6	Troubleshooting Guide.....	23
Tools Needed For Assembly.....	6	Parts List.....	24
Carton Contents	7		

WARRANTY

FULL ONE YEAR WARRANTY

If this tool fails due to a defect in material or workmanship within one year of date of purchase, Sears will at its option repair or replace it free of charge.

Return this tool to a Sears Service Center for repair, or to place of purchase for replacement.

This warranty gives you specific legal rights, and you may also have other rights which may vary from state to state.

Sears, Roebuck and Co., Dept. 817 WA, Hoffman Estates, IL 60179

▲ WARNING

Some dust created by power sanding, sawing, grinding, drilling and other construction activities contains chemicals known (to the State of California) to cause cancer, birth defects or other reproductive harm. Some examples of these chemicals are:

- Lead from lead-based paints
- Crystalline silica from bricks, cement and other masonry products
- Arsenic and chromium from chemically treated lumber

Your risk from these exposures varies, depending on how often you do this type of work. To reduce your exposure to these chemicals, work in a well ventilated area and work with approved safety equipment such as dust masks that are specially designed to filter out microscopic particles.

PRODUCT SPECIFICATIONS

MOTOR

Power Source.....	120 V AC, 60HZ, 15 Amp
Horsepower.....	2.5HP (Max. Developed)
Arbor Shaft Size	5/8"
Speed.....	4800 RPM (No load)
Brake.....	Electric
Double Insulated.....	Yes

MITER SAW

Cutting Capacity:

Crosscut.....	2-5/8" x 5-1/2"
Miter 45° R.&L.....	2-5/8" x 3-1/2"
Bevel 45° L.....	1-1/2" x 5-1/2"
45° Miter and 45° Bevel.....	1-1/2" x 3-1/2"

Rotating Table:

Diameter.....	12-5/8"
Miter Detent Stops.....	0, 15, 22-1/2, 31.6, 45° R. & L.
Bevel Positive Stops.....	0, 45°
Base Dimensions.....	20-1/2" x 16-1/4"
Dust Collection.....	Yes
Extension Wings.....	Yes
Net Weight.....	33 Lbs

▲ WARNING

To avoid electrical hazards, fire hazards or damage to the tool, use proper circuit protection.

This tool is wired at the factory for 110-120 Volt operation. It must be connected to a 110-120 Volt / 15 Ampere time delay fuse or circuit breaker. To avoid shock or fire, replace power cord immediately if it is worn, cut or damaged in any way.

Before using your tool, it is critical that you read and understand these safety rules. Failure to follow these rules could result in serious injury to you or damage to the tool.

POWER TOOL SAFETY

GENERAL SAFETY INSTRUCTIONS BEFORE USING THIS POWER TOOL

Safety is a combination of common sense, staying alert and knowing how to use your power tool.

▲ WARNING

To avoid mistakes that could cause serious injury, do not plug the tool in until you have read and understood the following.

- 1. READ** and become familiar with the entire Operators Manual. **LEARN** the tool's application, limitations and possible hazards.
 - 2. KEEP GUARDS IN PLACE** and in working order.
 - 3. REMOVE ADJUSTING KEYS AND WRENCHES.** Form the habit of checking to see that keys and adjusting wrenches are removed from the tool before turning ON.
 - 4. KEEP WORK AREA CLEAN.** Cluttered areas and benches invite accidents.
 - 5. DON'T USE IN DANGEROUS ENVIRONMENTS.** Don't use power tools in damp locations, or expose them to rain or snow. Keep work area well lighted.
 - 6. KEEP CHILDREN AWAY.** All visitors and bystanders should be kept a safe distance from work area.
 - 7. MAKE WORKSHOP CHILD PROOF** with padlocks, master switches, or by removing starter keys.
 - 8. DON'T FORCE THE TOOL.** It will do the job better and safer at the rate for which it was designed.
 - 9. USE THE RIGHT TOOL.** Do not force the tool or an attachment to do a job for which it was not designed.
 - 10. USE PROPER EXTENSION CORDS.** Make sure your extension cord is in good condition. When using an extension cord, be sure to use one heavy enough to carry the current your product will draw. An undersized cord will result in a drop in line voltage and in loss of power which will cause the tool to overheat. The table on page 5 shows the correct size to use depending on cord length and nameplate ampere rating. If in doubt, use the next heavier gauge. The smaller the gauge number, the heavier the cord.
 - 11. WEAR PROPER APPAREL.** Do not wear loose clothing, gloves, neckties, rings, bracelets, or other jewelry which may get caught in moving parts. Nonslip footwear is recommended. Wear protective hair covering to contain long hair.
 - 12. ALWAYS WEAR EYE PROTECTION.** Any power tool can throw foreign objects into the eyes and could cause permanent eye damage. **ALWAYS** wear Safety Goggles (not glasses) that comply with ANSI Safety standard Z87.1 Everyday eyeglasses have only impact –resistance lenses. They ARE NOT safety glasses. Safety Goggles are available at Sears. **NOTE:** Glasses or goggles not in compliance with ANSI Z87.1 could seriously injure you when they break.
- 
- The image shows a pair of safety goggles with a black strap and clear lenses. The text 'WEAR YOUR SAFETY GOGGLES' is printed on the top of the frame, and 'SAFETY GOGGLES' is printed on the side of the frame. There is also a small logo on the bottom right of the frame.
- 13. WEAR A FACE MASK OR DUST MASK.** Sawing operation produces dust.
 - 14. SECURE WORK.** Use clamps or a vise to hold work when practical. It's safer than using your hand and it frees both hands to operate the tool.
 - 15. DISCONNECT TOOLS FROM POWER SOURCE** before servicing, and when changing accessories such as blades, bits and cutters.
 - 16. REDUCE THE RISK OF UNINTENTIONAL STARTING.** Make sure switch is in the OFF position before plugging the tool in.
 - 17. USE RECOMMENDED ACCESSORIES.** Consult this Operators Manual for recommended accessories. The use of improper accessories may cause risk of injury to yourself or others.
 - 18. NEVER STAND ON THE TOOL.** Serious injury could occur if the tool is tipped or if the cutting tool is unintentionally contacted.
 - 19. CHECK FOR DAMAGED PARTS.** Before further use of the tool, a guard or other part that is damaged should be carefully checked to determine that it will operate properly and perform its intended function – check for alignment of moving parts, binding of moving parts, breakage of parts, mounting, and any other conditions that may affect its operation. A guard or other part that is damaged should be properly repaired or replaced.
 - 20. NEVER LEAVE THE TOOL RUNNING UNATTENDED. TURN THE POWER "OFF".** Don't walk away from a running tool until the blade comes to a complete stop & unplug the unit.
 - 21. DON'T OVERREACH.** Keep proper footing and balance at all times.
 - 22. MAINTAIN TOOLS WITH CARE.** Keep tools sharp and clean for best and safest performance. Follow instructions for lubricating and changing accessories.
 - 23. WARNING:** Dust generated from certain materials can be hazardous to your health. Always operate saw in well-ventilated area and provide for proper dust removal.

COMPOUND MITER SAW SAFETY

SPECIFIC SAFETY INSTRUCTIONS FOR THIS COMPOUND MITER SAW

- 1. USE ONLY CROSS-CUTTING SAW BLADES.** When using carbide tipped blades, make sure they have a negative hook angle.
IMPORTANT: DO NOT USE THIN KERF BLADES- they can deflect and contact guard and can cause possible injury to the operator.
- 2. DO NOT** operate the miter saw until it is completely assembled and installed according to these instructions.
- 3. IF YOU ARE NOT** thoroughly familiar with the operation of miter saws, seek guidance from your supervisor, instructor, or other qualified person.
- 4. ALWAYS** hold the work firmly against the fence and table. **DO NOT** perform any operation free hand (use clamp wherever possible).
- 5. KEEP HANDS** out of the path of the saw blade. If the workpiece you are cutting would cause your hands to be within 7-1/4" inches of the saw blade, the workpiece should be clamped in place before making the cut.
- 6. BE SURE** the blade is sharp, runs freely, and is free of vibration.
- 7. ALLOW** the motor to come up to full speed before starting a cut.
- 8. KEEP THE MOTOR AIR SLOTS CLEAN** and free of chips or dust.
- 9. ALWAYS MAKE SURE** all handles are tight before cutting, even if the table is positioned in one of the positive stops.
- 10. BE SURE** both the blade and the collar are clean and the arbor bolt is tightened securely.
- 11. USE** only blade collars specified for your saw.
- 12. NEVER** use blades larger or smaller in diameter than 10-inches.
- 13. NEVER** apply lubricants to the blade when it is running.
- 14. ALWAYS** check the blade for cracks or damage before operation. Replace a cracked or damaged blade immediately.
- 15. NEVER** use blades recommended for operation at less than 4800 RPM.
- 16. ALWAYS** keep the blade guards in place and use at all times.
- 17. NEVER** reach around the saw blade.
- 18. MAKE SURE** the blade is not contacting the workpiece before the switch is turned ON.
- 19. IMPORTANT:** After completing the cut, release the power switch and wait for the blade to stop before returning the saw to the raised position.
- 20. MAKE SURE** the blade has come to a complete stop before removing or securing the workpiece, changing the workpiece angle, or changing the angle of the blade.
- 21. NEVER** cut metals or masonry products with this tool. This miter saw is designed for use on wood and wood-like products.
- 22. NEVER** cut small pieces. If the workpiece being cut would cause your hand or fingers to be within 7-1/4" inches of the saw blade the workpiece is too small.
- 23. PROVIDE** adequate support to the sides of the saw table for long work pieces.
- 24. NEVER** use the miter saw in an area with flammable liquids or gases.
- 25. NEVER** use solvents to clean plastic parts. Solvents could possibly dissolve or otherwise damage the material.
- 26. SHUT OFF** the power before servicing or adjusting the tool.
- 27. DISCONNECT** the saw from the power source and clean the machine when finished using.
- 28. MAKE SURE** the work area is clean before leaving the machine.
- 29. SHOULD** any part of your miter saw be missing, damaged, or fail in any way, or any electrical component fail to perform properly, shut off the switch and remove the plug from the power supply outlet. Replace missing, damaged, or failed parts before resuming operation.

ELECTRICAL REQUIREMENTS

▲ WARNING

POWER SUPPLY AND MOTOR SPECIFICATIONS

The AC motor used in this saw is a universal, nonreversible type. See "MOTOR" in the "PRODUCT SPECIFICATIONS" section on page 2.

To avoid electrical hazards, fire hazards, or damage to the tool, use proper circuit protection. Your saw is wired at the factory for 120V operation. Connect to a 120V, 15 Amp circuit and use a 15 amp. time delay fuse or circuit breaker. To avoid shock or fire, if power cord is worn or cut, or damaged in any way, have it replaced immediately.

ELECTRICAL REQUIREMENTS AND SAFETY

ELECTRICAL REQUIREMENTS – cont'd

DOUBLE INSULATED

The power tool is double insulated to provide a double thickness of insulation between you and tool's electrical system. All exposed metal parts are isolated from the internal metal motor components with protecting insulation.

Replacement parts – When servicing use only identical replacement parts.

Polarized plugs – This saw has a plug that looks like the one shown below:

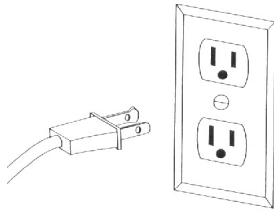

To reduce the risk of electrical shock, this saw has a polarized plug (one blade is wider than the other). This plug will fit in a polarized outlet only one way. If the plug does not fit fully in the outlet, reverse the plug. If it still does not fit, contact a qualified electrician to install the proper outlet. Do not change the plug in any way.

▲ WARNING

Double insulation does not take the place of normal safety precautions when operating this tool.

To avoid electrocution:

1. Use only identical replacement parts when servicing a tool with double insulation. Servicing should be performed by a qualified technician.
2. Do not use power tools in wet or damp locations or expose them to rain or snow.

MOTOR SAFETY PROTECTION IMPORTANT:

To avoid motor damage, the motor should be blown out or vacuumed frequently to keep sawdust from interfering with the motor ventilation.

1. **CONNECT** this saw to a 120V, 15 amp. circuit with a 15 amp. time delay fuse or circuit breaker. Using the wrong size fuse can damage the motor.
2. **If the motor won't start**, release the trigger switch immediately. **UNPLUG THE SAW.** Check the saw blade to make sure it turns freely. If the blade is free, try to start the saw again. If the motor still does not start, refer to the **"TROUBLESHOOTING GUIDE"**
3. **If the tool suddenly stalls** while cutting wood, release the trigger switch, unplug the tool, and free the blade from the wood. The saw may now be started and the cut finished.

4. **FUSES** may "blow" or circuit breakers may trip frequently if:

- a. **MOTOR** is overloaded – overloading can occur if you feed too rapidly or make too many start/stops in a short time.
 - b. **LINE VOLTAGE** is more than 10% above or below the nameplate voltage rating. For heavy loads, the voltage at motor terminals must equal the voltage specified on the nameplate.
 - c. **IMPROPER** or dull saw blades are used.
5. Most motor troubles may be traced to loose or incorrect connections, overload, low voltage or inadequate power supply wiring. Always check the connections, the load and supply circuit if the motor doesn't run well. Check minimum gauge for the length of cord you are using on the chart below.

GUIDELINES FOR EXTENSION CORDS

Use a proper extension cord. Make sure your extension cord is in good condition. When using an extension cord, be sure to use one heavy enough to carry the current your product will draw. An undersized cord will cause a drop in line voltage, resulting in loss of power and cause overheating. The table below shows the correct size to use depending on cord length and nameplate ampere rating. If in doubt, use the next heavier gauge. The smaller the gauge number, the heavier the cord.

Be sure your extension cord is properly wired and in good condition. Always replace a damaged extension cord or have it repaired by a qualified person before using it. Protect your extension cords from sharp objects, excessive heat and damp or wet areas.

Use a separate electrical circuit for your tools. This circuit must not be less than # 12 wire and should be protected with a 15 Amp time delay fuse. Before connecting the tool to the power line, make sure the switch is in the OFF position and the electric current is rated the same as the current stamped on the motor nameplate, running at a lower voltage will damage the motor.

MINIMUM GAUGE FOR EXTENSION CORDS (AWG)

		(When using 120 volts only)			
Ampere	Rating	Total length of cord in feet			
		25'	50'	100'	150'
0	6	18	16	16	14
6	10	18	16	14	12
10	12	16	16	14	12
12	16	14	12	not recommended	

CAUTION: In all cases make certain the receptacle in question is properly grounded. If you are not sure have a certified electrician, check the receptacle.

ACCESSORIES AND ATTACHMENTS

RECOMMENDED ACCESSORIES

▲ WARNING

- Use only accessories recommended for this miter saw. Follow instructions that accompany accessories. Use of improper accessories may cause hazards.
- The use of any cutting tool except 10 inch saw blades that meet the requirements under recommended accessories is prohibited. Do not use accessories such as shaper cutters or dado sets. Ferrous metal cutting, the use of abrasive wheels and the cutting of masonry products are prohibited.
- Do not attempt to modify this tool or create accessories not recommended for use with this tool. Any such alteration or modification is misuse and could result in a hazardous condition leading to possible serious injury.

ACCESSORIES

Visit your Sears Hardware Department or see the Sears Power and Hand Tool Catalog to purchase recommended accessories for this power tool.

▲ WARNING

To avoid the risk of personal injury, do not modify this power tool or use accessories not recommended by Sears.

▲ WARNING

Read warnings and conditions on your CARBIDE TIPPED SAW BLADE. Do not operate the saw without the proper saw blade guard in place. Carbide is a very hard but brittle material. Care should be taken while mounting, using, and storing carbide tipped blades to prevent accidental damage. Slight shocks, such as striking the tip while handling, can seriously damage the blade. Foreign objects in the workpiece, such as wire or nails, can also cause tips to crack or break off. Before using, always visually examine the blade and tips for bent teeth, cracks, breakage, missing or loose tips, or other damage. Do not use if damage is suspected. Failure to heed safety instructions and warnings can result in serious bodily injury.

TOOLS NEEDED FOR ASSEMBLY



Phillips screwdriver

CARTON CONTENTS

UNPACKING YOUR MITER SAW

▲ WARNING

To avoid injury from unexpected starting or electrical shock, do not plug the power cord into a source of power during unpacking and assembly. This cord must remain unplugged whenever you are adjusting/assembling the saw.

1. Remove the miter saw from the carton. **IMPORTANT:** Do not lift the miter saw by the switch handle or miter table handle. It may cause misalignment. Lift only by the built-in carry handle located at the top of the machine.

2. Place the saw on a secure stationary work surface.
3. Separate all parts from the packing material. Check each one with the illustration below to make certain all items are accounted for, before discarding any packing material.

▲ WARNING

If any part is missing or damaged, do not attempt to assemble the miter saw, or plug in the power cord until the missing or damaged part is correctly replaced. To avoid electric shock, use only identical replacement parts when servicing double insulated tools.

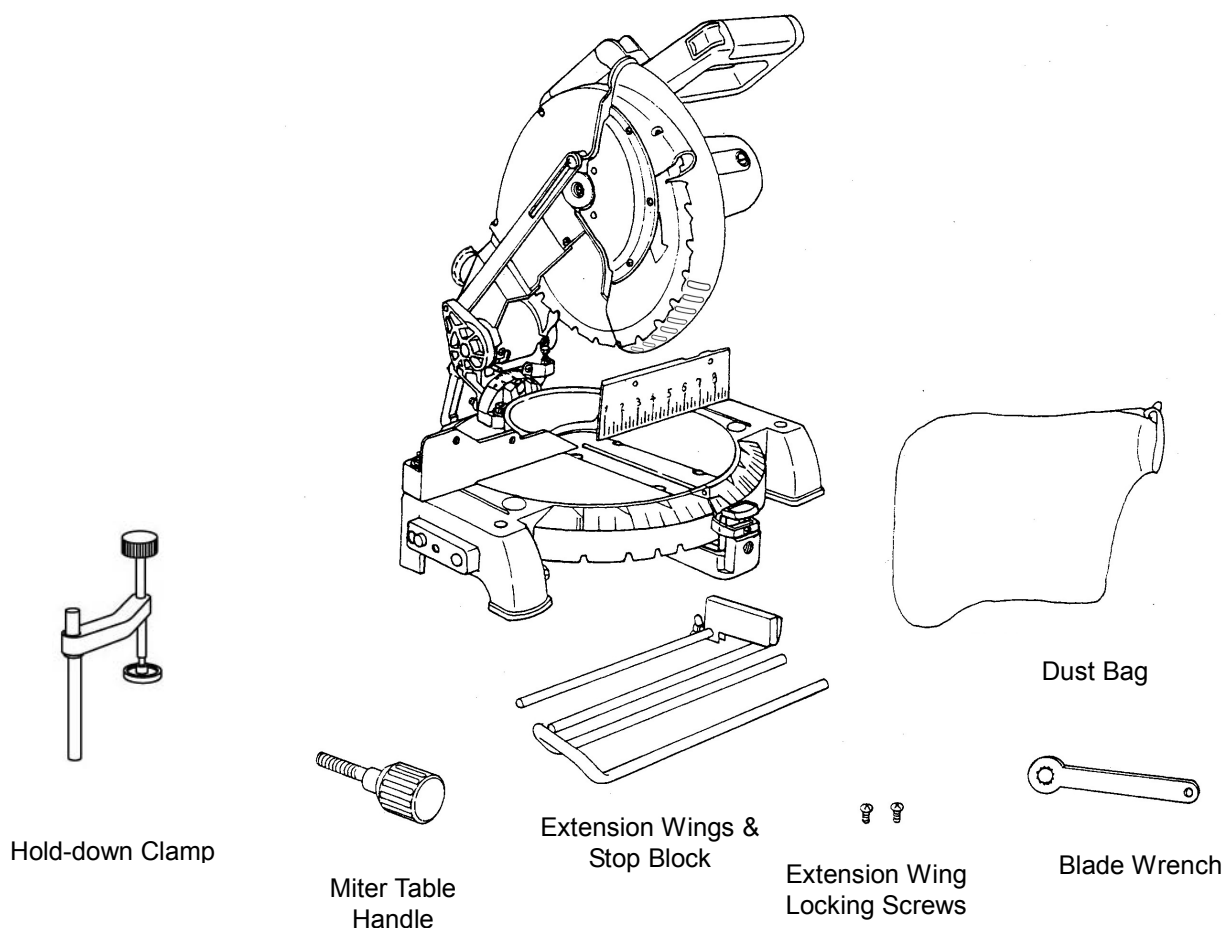

KNOW YOUR COMPOUND MITER SAW

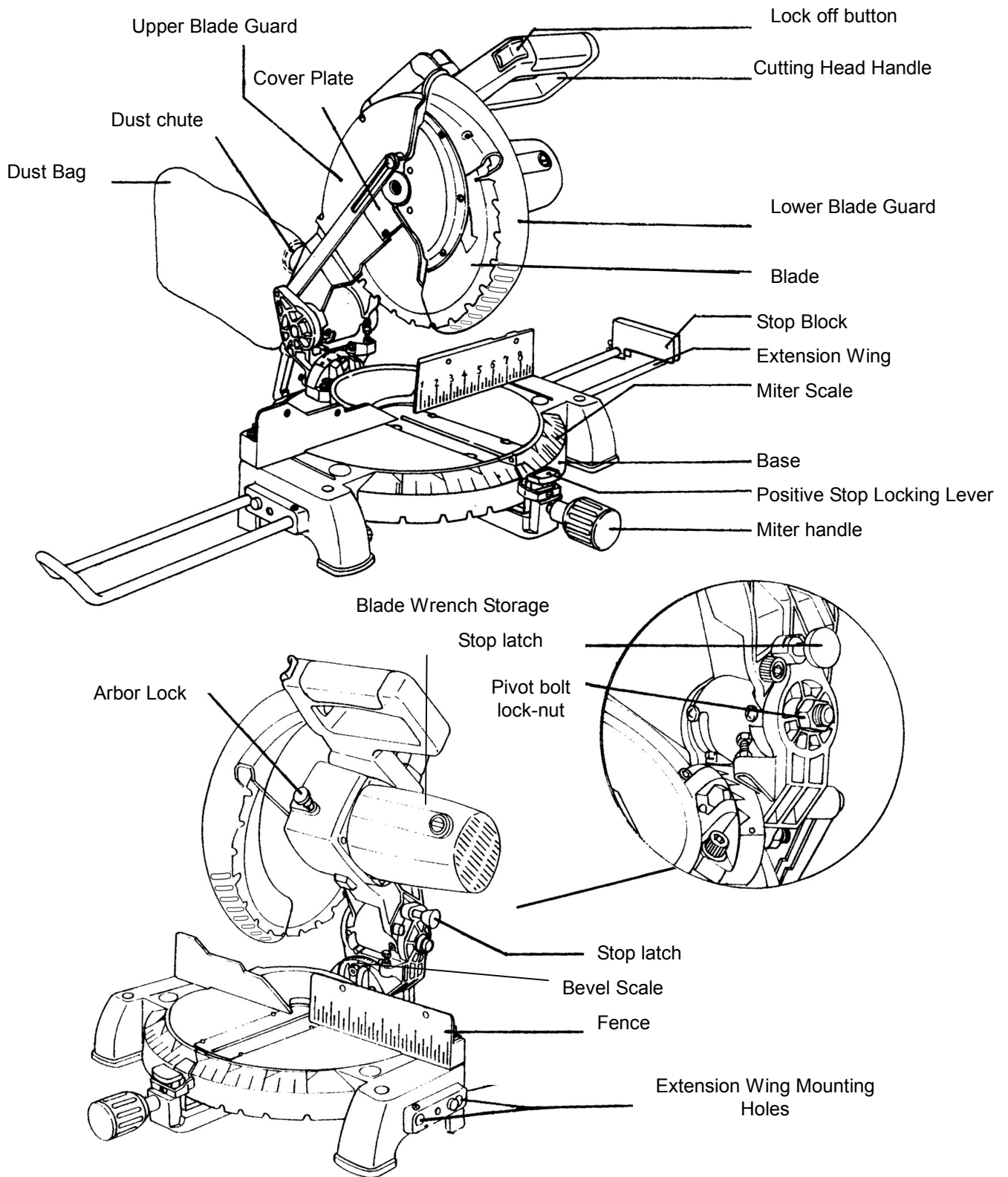

GLOSSARY OF TERMS

CRAFTSMAN COMPOUND MITER SAW TERMS

ARBOR LOCK – Allows the user to keep the blade from rotating while tightening or loosening the arbor locking bolt during blade replacement or removal.

BASE – Supports the table, holds accessories and allows for workbench or leg set mounting.

BEVEL LOCKING HANDLE – Locks the miter saw at a desired bevel angle.

BEVEL SCALE – To measure the bevel angle of the saw blade 0° to 45° left.

COVER PLATE SCREW – Loosen this screw and rotate the plate for access to the blade arbor locking bolt.

DUST CHUTE – Exhausts debris away from the user.

EXTENSION WING – Extends the width of the work table for support while cutting long work pieces. They can be used with or without a stop block as an additional side fence.

FENCE – Helps to keep the workpiece from moving when sawing. Scaled to assist with accurate cutting.

HAND HOLD – Location of hands for transportation.

SAFETY LOCK-OFF BUTTON – Yellow button on handle must be pushed forward to activate the trigger switch.

LOWER BLADE GUARD – Helps protect your hands from the blade in the raised position, it retracts as the blade is lowered.

MITER HANDLE – Used to rotate the saw to the right or left cutting position.

MITER SCALE – To measure the miter angle 0° to 45° left, 0° to 45° right.

MITER SPRING LOCK – Used in combination with the miter handle, it locks the miter saw at a preset positive stop for the desired miter angle.

MOUNTING HOLES – To mount the miter saw to a stable surface.

ON/OFF TRIGGER SWITCH – To prevent the trigger from being accidentally engaged, a lock-off slide switch is provided. To start the tool, push the lock-off slide switch forward and squeeze the trigger. Release the trigger to stop the miter saw.

STOP LATCH – Locks the miter saw in the lowered position for compact storage and transportation.

SWITCH HANDLE – The cutting head handle contains the trigger switch and a safety lock-off slide switch. The blade is lowered into the workpiece by pushing down on the handle. The saw will return to its upright position when the handle is released.

WARNING LABELS – Read and understand for your own safety. Always make certain these are in place & legible.

WRENCH STORAGE – Convenient storage to prevent misplacing the blade wrench.

WOODWORKING TERMS

ARBOR – The shaft on which a blade is mounted.

BEVEL CUT – An angle cut made through the face of the workpiece.

COMPOUND CUT – A simultaneous bevel and miter cut.

CROSS CUT – A cut made across the width or grain of the workpiece.

FREEHAND – Performing a cut without using a fence (guide), hold down or other proper device to prevent the workpiece from twisting during the cutting operation.

GUM – A sticky sap from wood products.

HEEL – Misalignment of the blade.

KERF – The amount of material removed by blade cut.

MITER CUT – An angle cut made across the width or grain of the workpiece.

RESIN – A sticky sap that has hardened.

REVOLUTIONS PER MINUTE (RPM) – The number of turns completed by a spinning object in one minute.

SAW BLADE PATH – The area of the workpiece or table top directly in line with the travel of the blade or the part of the workpiece which will be cut.

SET – The distance between two saw blade tips, bent outward in opposite directions to each other. The further apart the tips are, the greater the set.

WORKPIECE – The item being cut. The surfaces of a workpiece are commonly referred to as faces, ends, and edges.

ASSEMBLY AND ADJUSTMENTS

ASSEMBLY INSTRUCTIONS

▲ WARNING

To avoid injury, do not connect this miter saw to the power source until it is completely assembled and adjusted, and you have read and understood this Operators Manual.

INSTALLING THE MITER HANDLE (FIG. A)

1. Thread the miter handle (1) into the hole (2) located at the front of the miter table.

Fig. A

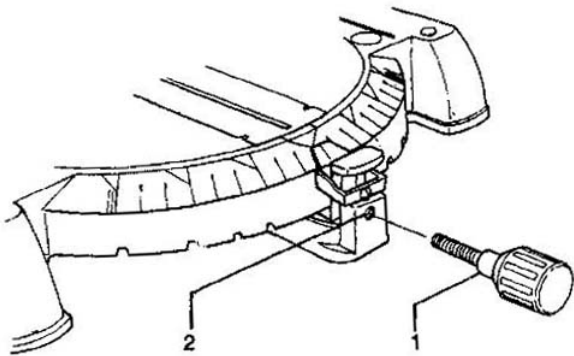

SAW BLADE WRENCH (FIG. B)

1. For convenient storage and prevention of loss, there is a slot (1) in the rear of the cutting head handle (2) for storing the blade wrench (3) when not in use.

Fig. B

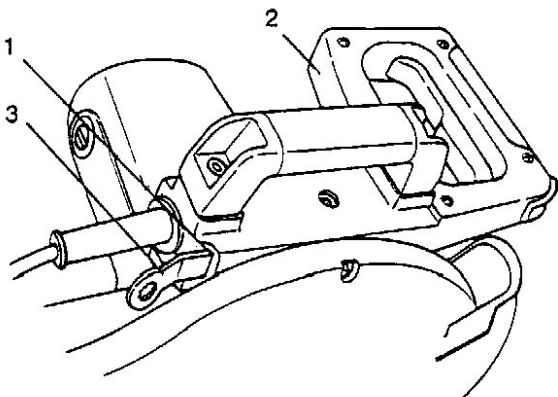

CUTTING HEAD (FIG. C)

Raising

1. Push down slightly on the cutting handle (1).
2. Pull out the stop latch knob (2).
3. Allow the cutting head (3) to rise to the up position.

▲ WARNING

To avoid injury and damage to the saw, transport or store the miter saw with the cutting head locked in the down position. Never use the stop latch to hold the cutting head in a down position for cutting operations.

Fig. C

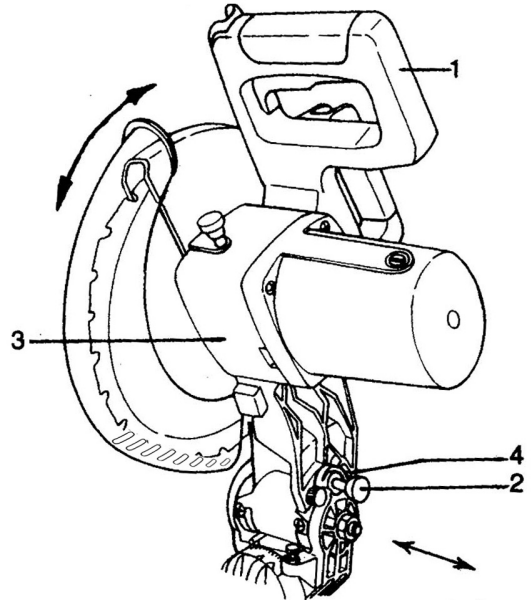

Locking

When transporting or storing the miter saw, the cutting head should always be locked in the down position.

1. Push the cutting head (3) down to its lowest position.
2. Push the stop latch (2) into the locking hole (4).

IMPORTANT: To avoid damage, never carry the miter saw by the switch handle, the cutting arm, or the miter table handle. ALWAYS use the designated carrying handle.

INSTALLING THE DUST BAG (FIG. D)

1. Squeeze the metal collar wings (2) of the dust bag (1).
2. Place the dust bag neck opening around the exhaust port (3), and release the metal collar wings.

Fig. D

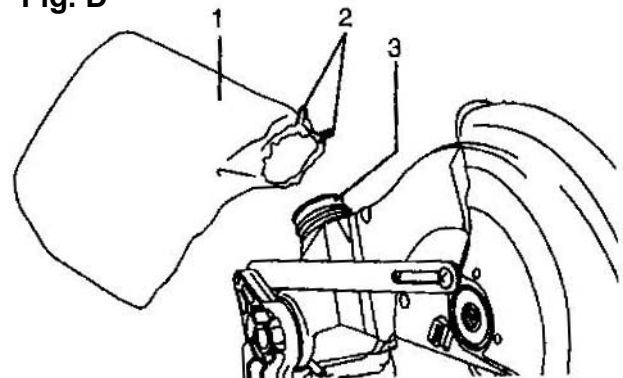

INSTALLING EXTENSION WINGS (FIG. E)

▲ WARNING

To avoid injury or possible damage to the tool, support long work pieces by installing the extension wings to extend the work support surface.

When using extension and stop block on the right side, hold down clamp must also be in right side. Using hold down clamp on the left side during this operation can cause kick-back and serious injury to the operator.

INSTALLING THE STOP BLOCK (FIG. E):

1. Slide the stop block (1) onto the extension wing (2)
2. Thread the wing bolt (4) into the stop block and tighten.

INSTALLING THE EXTENSION WINGS (FIG. E):

1. Place the extension wing into the mounting holes (5) provided in the miter saw base.
2. Thread the extension wing locking screw (6) into the threaded hole (7) and tighten to secure extension in place.

Fig. E

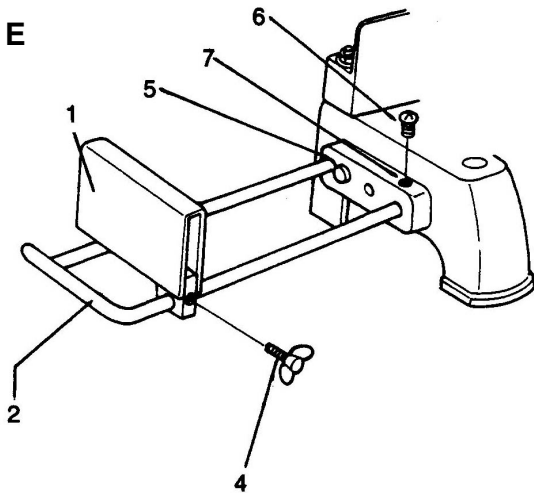

REMOVING OR INSTALLING THE BLADE

▲ WARNING

Only use a 10-inch diameter blade. To avoid injury from an accidental start, make sure the switch is in the OFF position and plug is not connected to the power source outlet.

REMOVING (Fig. F, G, H)

▲ WARNING

1. Unplug the saw from the outlet.
2. Allow the blade assembly to rise to the uppermost position. Raise the lower blade guard (1) to the upper position. (Fig. F)
3. Loosen the cover plate screw (2) with a Phillips screwdriver (Fig. F).
4. Rotate the cover plate (3) to expose the arbor bolt (4) - (Fig. F).
5. Place the blade end wrench over the arbor bolt.

Fig. F

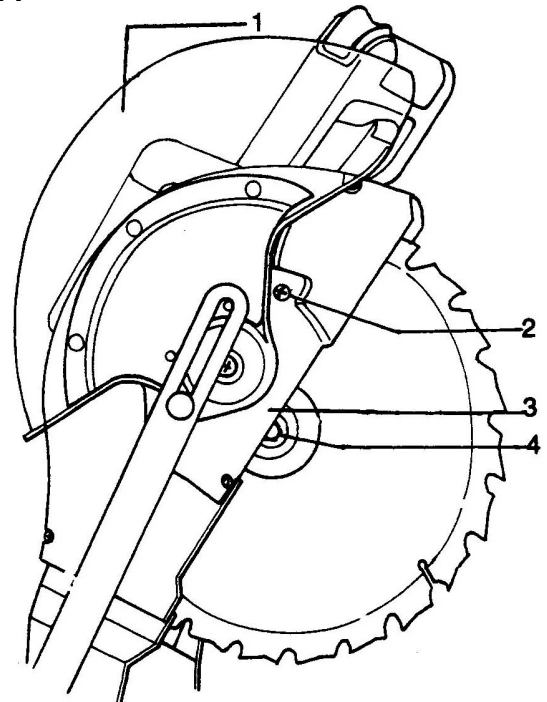

6. Locate the arbor lock (5) on the motor, below the miter saw switch handle. (Fig. G)

7. Press the arbor lock, holding it in firmly while turning the blade wrench clockwise. The arbor lock will engage after turning the wrench. Continue to hold the arbor locking to keep it engaged, while turning the wrench clockwise to loosen the arbor bolt.

8. Raise the lower clear plastic blade guard (1) to the upright position. (Fig. F)

Fig. G

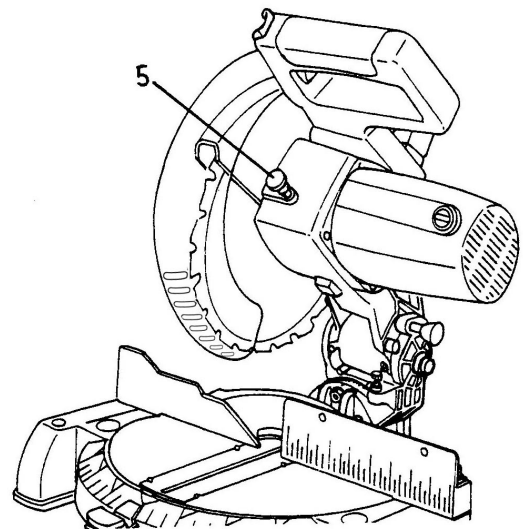

REMOVING – cont'd

9. Remove the arbor bolt/washer (4), laser guide (6), and the blade (7). Do not remove the inner blade collar. (Fig. H)

NOTE: Pay attention to the pieces removed, noting their position and direction they face. Wipe the laser guide clean of any sawdust before installing the new blade.

Fig. H

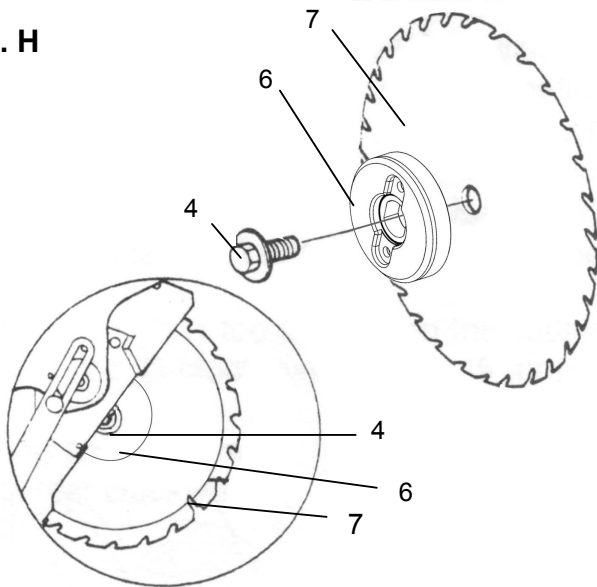

INSTALLING BLADE (Fig. F, G, H)

1. Install a 10" blade, making sure the rotation arrow on the blade matches the clockwise rotation arrow on the upper guard, and the blade teeth are pointing downward.
2. Place the laser guide (6) against the blade and on the arbor. Thread the arbor bolt (4) into the arbor in a counterclockwise direction. **(Fig. H)**

IMPORTANT: Make sure the flats of the laser guide are engaged with the flats on the arbor shaft.

3. Place the blade wrench on the arbor bolt.
4. Press the arbor lock (5), holding it in firmly while turning the blade wrench counterclockwise. When it engages, continue to press the arbor lock in, while tightening the arbor bolt securely. **(Fig. G)**
5. Rotate the cover plate (3) back until the slot in the cover plate engages with the cover plate screw (2). Tighten the screw with a Phillips screwdriver **(Fig. F)**.
6. Lower the blade guard (1). **(Fig. F)**
7. Be sure the arbor lock is released so the blade turns freely.

▲ WARNING

- To avoid injury, never use the saw without the cover plate secure in place. It keeps the arbor bolt from falling out if it accidentally loosens, and helps prevent the spinning blade from coming off the saw.
- Make sure the collars are clean and properly arranged. Lower the blade into the lower table and check for any contact with the metal base or the turntable.
- To avoid injury from an accidental start, make sure the switch is in the OFF position and the plug is not connected to the power source outlet.

INSTALLING THE HOLD-DOWN CLAMP (FIG. H-1)

Place the Hold-down Clamp (1) in the desired mounting hole (2).

Fig. H-1

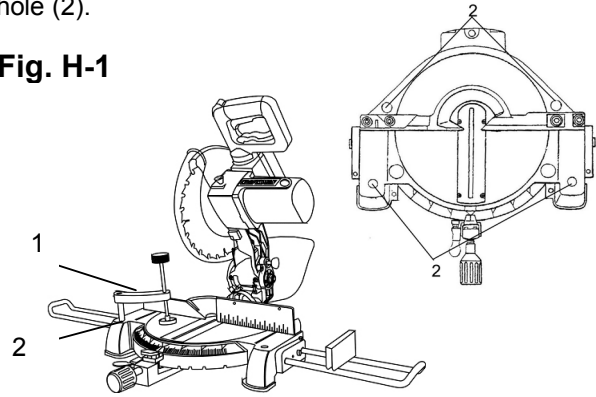

ADJUSTING FENCE SQUARENESS (Fig. I)

1. Loosen the four fence locking bolts (1).
2. Using a square, lay the heel of the square against the blade, and the rule against the fence (2) as shown.
3. Adjust the fence to be 90° to the blade and tighten the four fence locking screws.

CAUTION: If the saw has not been used recently, recheck blade squareness to the fence and readjust if needed.

Fig. I

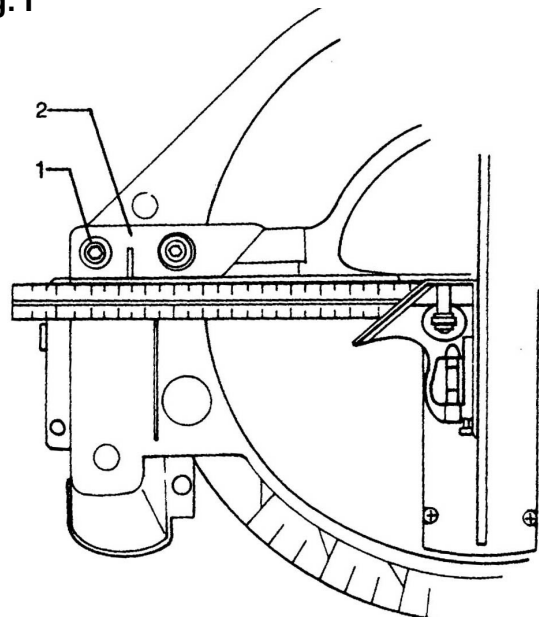

MITER SCALE (FIG. J)

The miter scale assists the user in setting the desired miter angles from 47° left to 47° right. The miter saw table has nine of the most common angle settings with positive stops (3) at 0°, 15°, 22.5°, 31.6° and 45°. These positive stops position the blade at the desired angle quickly and accurately.

To Adjust Miter Angles:

1. Unlock the miter table by turning the miter handle (1) counterclockwise.
2. While holding the positive-stop locking lever (2) down, grasp the miter handle and rotate the miter table left or right to the desired angle.
3. If the desired angle is one of the nine positive stops, release the positive-stop locking lever making sure the lever snaps into position.
4. If the miter angle desired is not one of the nine positive stops, simply lock the miter table into position by turning the miter handle in the clockwise direction.

Miter Angle Pointer Adjustment:

1. Position the miter table at zero degrees.
2. Loosen the pointer screw (4) and adjust the indicator to the 0° mark on the miter scale & retighten the screw.

Fig. J

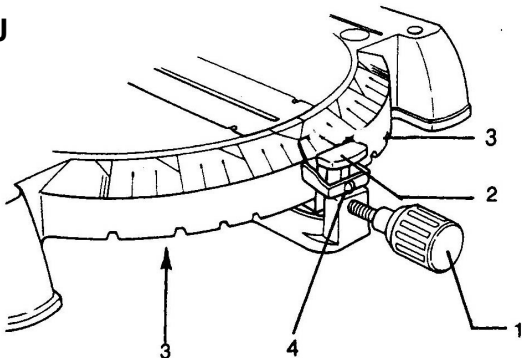

CUTTING ARM TRAVEL (FIG. K)

Cutting arm pivot adjustment

The pivot movement of the cutting arm (1) should not be too tight; restricting movement, nor too loose; affecting the accuracy of the saw cut. The correct locking nut (2) adjustment is snug, allowing no side-to-side arm movement. To adjust, tighten or loosen the adjusting nut (2).

Fig. K

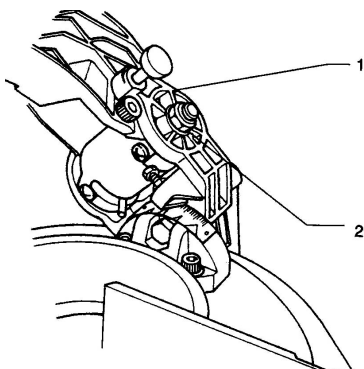

Cutting head downward travel adjustment (Fig. L)

▲ WARNING

To avoid injury from an accidental start, make sure the switch is in the OFF position and the plug is not connected to the power source outlet.

Before each cutting operation, check the position of the blade to make sure it does not contact any metal surface. If the blade contacts any metal surface, the depth of travel on the upper arm assembly must be adjusted.

1. Lower the blade as far as possible.
2. Loosen the locknut (3).
3. Turn the adjustment bolt (4) out (counterclockwise) to decrease the cutting depth or in (clockwise) to increase the cutting depth.
4. Rotate the blade manually to check for contact.
5. Repeat until adjusted properly, and tighten the locknut to secure the adjustment bolt into position.

Fig. L

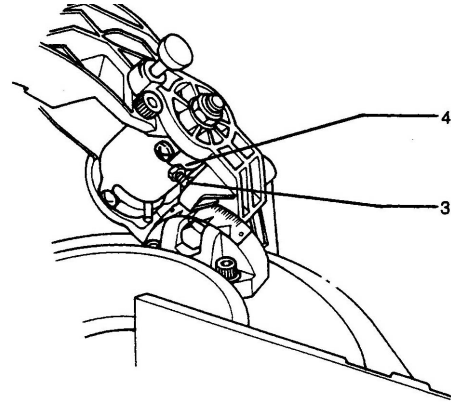

BEVEL STOP ADJUSTMENT (Fig. M & N)

▲ WARNING

To avoid injury from an accidental start, make sure the switch is in the OFF position and the plug is not connected to the power source outlet.

90° Bevel adjustment (Fig. M)

1. Loosen bevel lock handle (1) and tilt the cutting arm completely to the right. Tighten the bevel lock handle.
2. Place a combination square (2) on the miter table with the rule against the table and the heel of the square against the saw blade.
3. If the blade is not 90° square with the miter table, loosen the bevel lock handle, tilt the cutting head to the left, turn the bevel angle adjustment bolt (3) in or out with a 5mm hex wrench until the blade is square with the table.
4. Tilt the cutting arm to back to the right at 90° bevel and recheck for alignment.
5. Repeat steps 1 through 4 if further adjustment is needed.

Fig. M

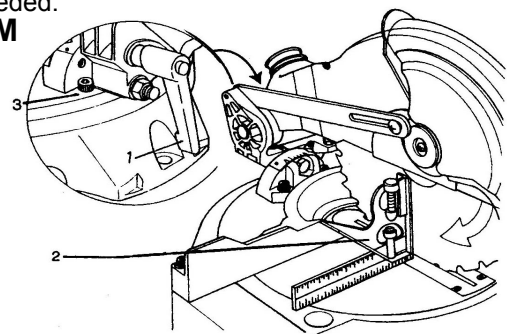

90° Bevel Pointer Adjustment (Fig. N)

1. When the blade is exactly 90° to the table loosen the bevel indicator screw (5) using a Phillips screwdriver.
2. Adjust bevel indicator (6) to the "0" mark (7) on the bevel scale and retighten the screw.

▲ WARNING

To avoid injury from an accidental start, make sure the switch is in the OFF position and the plug is not connected to the power source outlet.

45° Bevel Adjustment (Fig N)

1. Unlock the bevel lock handle and tilt the cutting head completely to the left.
2. Using a combination square, check to see if the blade angle is 45° to the table.
3. If the blade is not at 45° to the miter table, tilt the cutting arm to the right, turn the bevel angle adjustment bolt (4) in or out with a 5mm hex. wrench accordingly.
4. Tilt the cutting arm to the left to 45° bevel and recheck for alignment.
5. Repeat steps 1 through 4 until the blade is at 45° to the miter table.

Fig. N

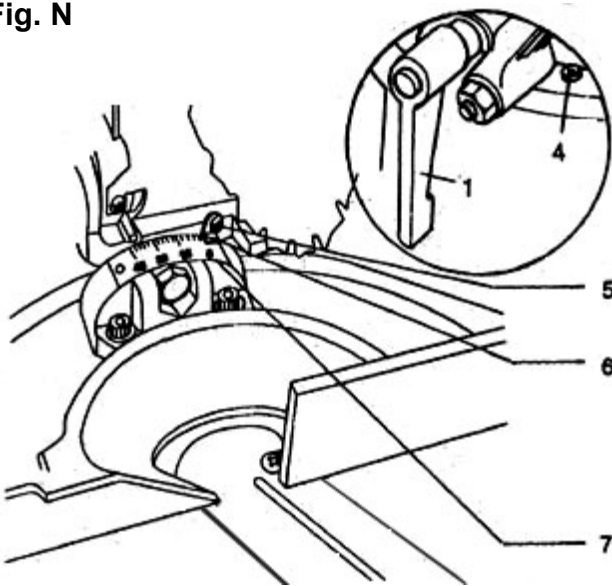

MOUNTING THE MITER SAW (Fig. O)

To avoid injury from unexpected saw movement:

- Before moving the saw, disconnect the power cord from the outlet, and lock the cutting arm in the lower position using the stop latch.

NOTE: The stop latch is for carrying or storing the tool. It is NOT to be used holding the saw while cutting.

- Never carry the miter saw by the power cord or by the switched handle. Carrying the tool by the power cord could cause damage to the insulation or wire connections resulting in electric shock or fire.
- To avoid injury from flying debris, do not allow visitors to stand behind the saw.
- Place the saw on a firm, level work-surface where there is room for handling and properly supporting the workpiece.

- Support the saw on a level work surface.
- Bolt or clamp the saw to its support.

Place the saw in the desired location, either on a work bench or recommended leg set. The base of the saw has three mounting holes (1).

- For stationary use, fasten the saw to a workbench.

- For portable use, fasten the saw to a 3/4" piece of plywood. This mounting board can then be clamped to a secure surface.

Fig. O

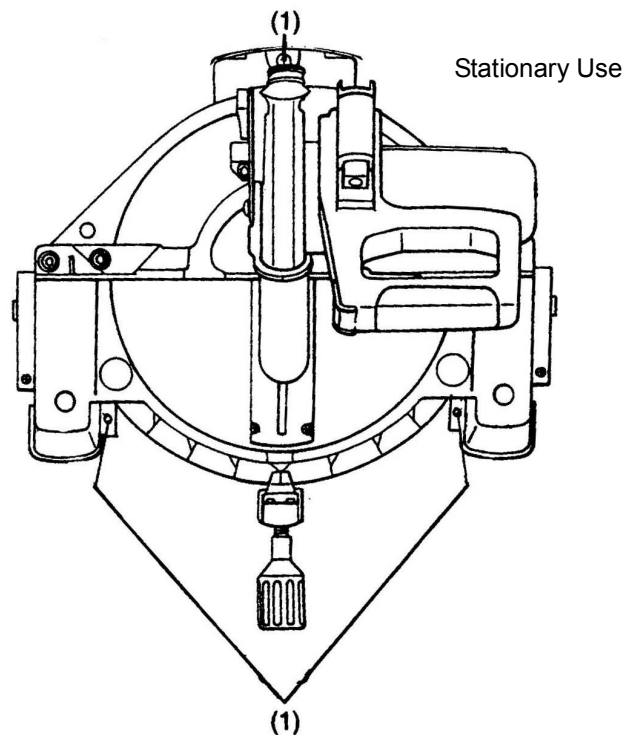
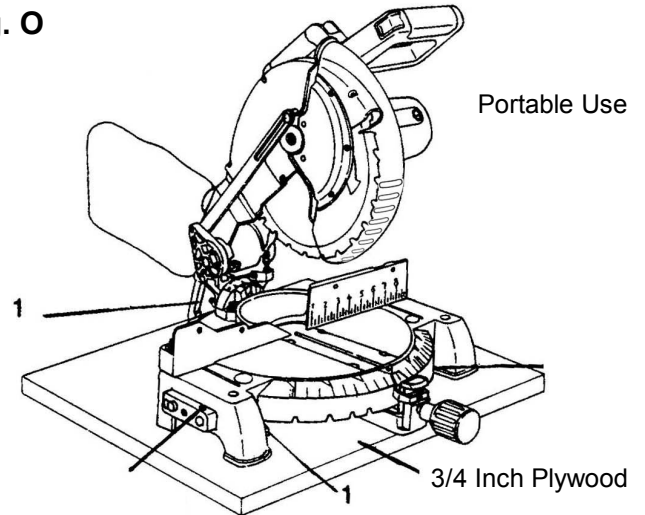

OPERATION

SAFETY INSTRUCTIONS FOR BASIC SAW OPERATIONS

BEFORE USING THE MITER SAW

▲ WARNING

To avoid mistakes that could cause serious, permanent injury, do not plug the tool in until the following steps are completed:

- Completely assemble and adjust the saw, following the instructions. **(ASSEMBLY AND ADJUSTMENTS)**
- Learn the use and function of the ON/OFF switch, lock-off switch, upper and lower blade guards, stop latch, bevel lock handle, and cover plate screws.
- Review and understand all safety instructions and operating procedures in this Operator's Manual. **(SAFETY & OPERATIONS)**
- Review the MAINTENANCE and TROUBLESHOOTING GUIDE for your miter saw.
- To avoid injury or possible death from electrical shock:
Make sure your fingers do not touch the plug's metal prongs when plugging or unplugging your miter saw. **(ELECTRICAL REQUIREMENTS AND SAFETY)**

BEFORE EACH USE

Inspect your saw.

- **Disconnect the miter saw.** To avoid injury from accidental starting, unplug the saw before any adjustments, including set-up and blade changes.
- **Compare the direction of rotation arrow** on the guard to the direction arrow on the blade. The blade teeth should always point downward at the front of the saw.
- **Tighten the arbor bolt.**
- **Tighten the cover plate screw.**
- **Check for damaged parts.** Check for:
 - Alignment of moving parts
 - Damaged electric cords
 - Binding of moving parts
 - Mounting holes
 - Function of arm return spring and lower guard:
Push the cutting arm all the way down, then let it rise until it stops. The lower guard should fully close. Follow instructions in TROUBLESHOOTING GUIDE for adjustment if necessary.
- Other conditions that may affect the way the miter saw works.

Keep all guards in place, in working order and properly adjusted.

If any part of this miter saw is missing, bent, damaged or broken in any way, or any electrical parts don't work, turn the saw off and unplug it. Replace damaged, missing, or defective parts before using the saw again.

- Maintain tools with care. Keep the miter saw clean for best and safest performance. Follow instructions for lubricating. Don't put lubricants on the blade while it's spinning.
- Remove all adjusting wrenches from the tool before turning it on.

USE ONLY RECOMMENDED ACCESSORIES

- Consult the ACCESSORIES and ATTACHMENTS section of this Operators Manual for recommended accessories. Follow the instructions that come with the accessory. The use of improper accessories may cause risk of injury to persons.
- Choose the correct 10 inch diameter blade for the material and the type of cutting you plan to do. **Do not use Thin Kerf blades.**
- Make sure the blade is sharp, undamaged and properly aligned. With the saw unplugged, push the cutting arm all the way down. Manually spin the blade and check for clearance. Tilt the miter head to a 45° bevel and repeat the test.
- Make sure the blade and arbor collars are clean.
- Make sure all clamps and locks are tight and there is no excessive play in any parts.

KEEP YOUR WORK AREA CLEAN

Cluttered areas and benches invite accidents.

▲ WARNING

To avoid burns or other fire damage, never use the miter saw near flammable liquids, vapors, or gases.

- **Plan ahead to protect your eyes, hands, face and ears.**
- **Know your miter saw.**

Read and understand the Operator's Manual and labels affixed to the tool. Learn its application and limitations as well as the specific potential hazards specific to this tool. To avoid injury from accidental contact with moving parts, don't do layout, assembly, or setup work on the miter saw.

- **Avoid accidental starting**
Make sure the switch is OFF before plugging the miter saw into a power outlet.

PLAN YOUR WORK

- Use the right tool. Don't force a tool or attachment to do a job it was not designed to do. Use a different tool for any workpiece that can't be held in a solidly braced, fixed position.

CAUTION: This machine is NOT designed for cutting masonry, masonry products & ferrous metals (steel, iron, and iron-based metals.) Use this miter saw to cut only wood and wood by-products. Other material may shatter, bind the blade, or create other dangers. Remove all nails that may be in the workpiece to prevent sparking that could cause a fire.

DRESS FOR SAFETY

Any power tool can throw foreign objects into the eyes. This can result in permanent eye damage. Everyday eyeglasses have only impact resistant lenses and are not safety glasses. Glasses or goggles not in compliance with ANSI Z87.1 could seriously injure you when they break.

- Do not wear loose clothing, gloves, neckties or jewelry (rings, watches). They can get caught and draw you into moving parts.
- Wear non-slip footwear.
- Tie back long hair.
- Roll long sleeves above the elbow.
- Noise levels vary widely. To avoid possible hearing damage, wear ear plugs when using any miter saw.
- For dusty operations, wear a dust mask along with safety goggles.

INSPECT YOUR WORKPIECE

Make sure there are no nails or foreign objects in the part of the workpiece being cut.

Plan your work to avoid small pieces that may bind, or that are too small to clamp and get a solid grasp on.

Plan the way you will grasp the workpiece from start to finish. Avoid awkward operations and hand positions. A sudden slip could cause your fingers or hand to move into the blade.

DON'T OVER-REACH

Keep good footing and balance. Keep your face and body to one side, out of the line of a possible kickback. NEVER stand in the line of the blade.

Never cut freehand:

- Brace your workpiece firmly against the fence and table stop so it will not rock or twist during the cut.
- Make sure there is no debris between the workpiece and the table or fence.

workpiece, fence and table that will let the workpiece shift after it is cut.

- Keep the cut off piece free to move sideways after it is cut off. Otherwise, it could get wedged against the blade and thrown violently.
- Only the workpiece should be on the saw's table.
- **Secure work.** Use clamps or a vise to help hold the work when it's practical.

USE EXTRA CAUTION WITH LARGE OR ODD SHAPED WORKPIECES.

- Use extra supports (tables, sawhorses, blocks, etc.) for workpieces large enough to tip.
- Never use another person as a substitute for a table extension, or as an additional support for a workpiece that is longer or wider than the basic miter saw table, or to help feed, support, or pull the workpiece.
- Do not use this saw to cut small pieces. If the workpiece being cut would cause your hand or fingers to be within 7-1/4" inches of the saw blade workpiece is too small. Keep hands and fingers out of the "no hands zone" area marked on the saws table.
- When cutting odd shaped workpieces, plan your work so it will not bind in the blade and cause possible injury. Molding, for example, must lie flat or be held by a fixture or jig that will not let it move when cut.
- Properly support round material such as dowel rods, or tubing, which have a tendency to roll when cut, causing the blade to "bite".

▲ WARNING

To avoid injury, follow all applicable safety instructions, when cutting non-ferrous metals:

- Use only saw blades specifically recommended for non-ferrous metal cutting.
- Do not cut metal workpieces that must be hand held. Clamp workpieces securely.
- Cut non-ferrous metals only if you are under the supervision of an experienced person.

WHEN SAW IS RUNNING

▲ WARNING

Don't allow familiarity from frequent use of your miter saw to result in a careless mistake. A careless fraction of a second is enough to cause a severe injury.

Before cutting, if the saw makes an unfamiliar noise or vibrates, stop immediately. Turn the saw OFF. Unplug the saw. Do not restart until finding and correcting the problem.

BODY AND HAND POSITION (FIG. P)

Proper positioning of your body and hands when operating the miter saw will make cutting easier and safer. Never place hands near the cutting area. Position hands at least 7-1/4" away from the path of the blade. Hold workpiece firmly against the fence to prevent movement toward the blade. Keep hands in position until the trigger has been released and the blade has completely stopped. Before making a cut, with the power switch in the OFF position bring the saw blade down to the workpiece to see the cutting path of the blade.

- Keep children away. Keep all visitors a safe distance from the miter saw. Make sure bystanders are clear of the miter saw and workpiece.
- Don't force tool. It will do the job better and safer at its designed rate. Feed the saw into the workpiece slowly with a firm downward motion.
- Before freeing jammed material:
 - Turn switch OFF.
 - Unplug the miter saw.
 - Wait for all moving parts to stop.
 - After finishing a cut, keep holding the upper blade assembly in the down position.
 - Release the switch, and wait for all moving parts to stop before moving your hands.
- If the blade doesn't stop within 6 seconds, unplug the saw and follow the instructions in **TROUBLESHOOTING GUIDE** section for adjusting the blade brake before using the saw again.

Fig. P

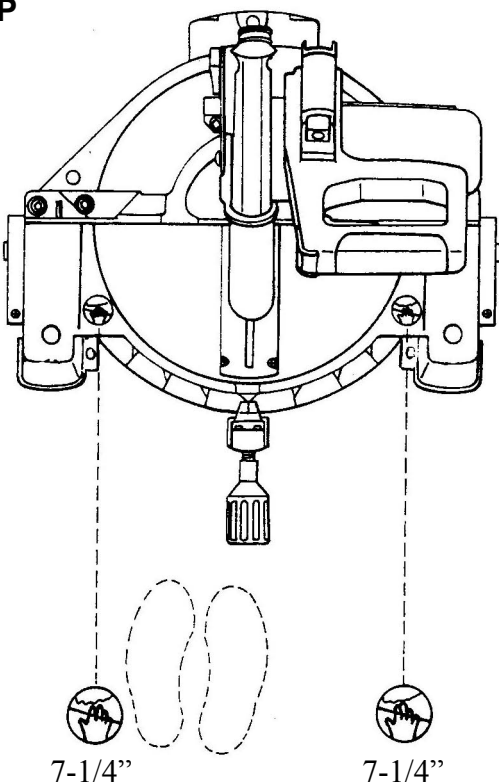

TURNING THE SAW ON (Fig. Q)

To reduce the likelihood of accidental starting, a thumb activated lock-OFF switch is located on top of the switch handle. The safety lock-OFF button (1) must be pushed forward before the trigger switch (2) can be activated and the miter saw started.

Make the switch child-proof. Insert a padlock through the hole (3) in the trigger switch and lock it. This will prevent children and other unauthorized users from turning the switch ON.

Fig. Q

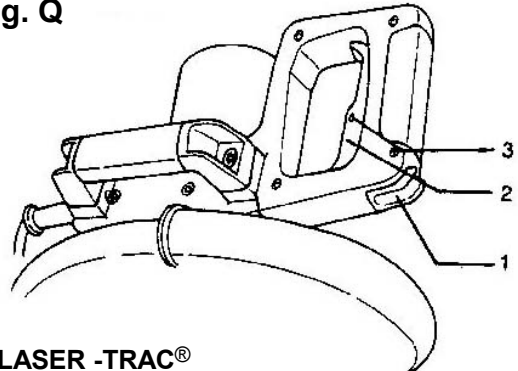

THE LASER -TRAC®

Your tool is equipped with our latest innovation, the Laser -Trac®, a battery powered device using Class IIIa laser beams. The laser beams will enable you to preview the miter blade path on the workpiece to be cut before you begin your operation.

▲ DANGER

Laser is activated when blade is rotating. Do not stare into beam or view directly with optical instruments. Do not remove the warning label affixed to the blade guard. Avoid direct eye contact with light source.

NOTE - The red laser line will appear as a dotted line when the motor is activated and the blade assembly is in the uppermost position. This broken line will assist you in aligning the mark on your workpiece with the cutting path of the saw blade. As you lower the blade assembly, the retractable guard will lift and turn the broken line into a solid red laser line.

Laser Warning label: Max output <5mW DIODE LASER: 630-670nm, Complies with 21CFR 1040.10 and 1040.11.

OPERATION OF LASER

With the blade assembly in the uppermost position:

1. Position your workpiece onto the miter saw.
2. Turn on the miter saw to activate the laser beam.
3. Verify the laser beam is aligned with the mark on the workpiece (**WARNING** - Do not lower the blade assembly during the alignment process).
4. If the mark on the workpiece is not aligned with the dotted laser line, turn off machine, wait for the blade to stop and reposition workpiece.
5. Turn on the miter saw and verify alignment.
6. Once alignment is achieved, secure workpiece with a clamping device and perform the cut.

MITER CUT (FIG. R)

When a miter cut is required, unlock the miter table by turning the miter handle (1) counterclockwise. While holding the miter handle, press down on the positive stop locking lever (2). Rotate the miter table to the right or left with the miter handle. When the table is in the desired position as shown on the miter scale (3), release the positive stop locking lever and tighten the miter handle. The table is now locked at the desired angle. Positive stops are provided at 0°, 15°, 22.5°, 31.6° and 45°.

IMPORTANT: Always tighten the miter table lock handle before performing a cut.

Fig. R

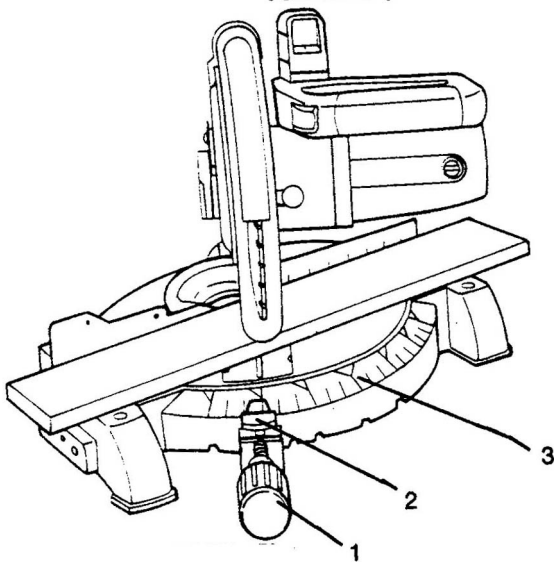

BEVEL CUT (FIG. S)

When a bevel cut is required, loosen the bevel lock handle (1). Tilt the cutting head to the desired angle as shown on the bevel scale (2). The blade can be positioned at any angle, from a 90° straight cut (0° on the scale) to a 45° left bevel. Tighten the lock handle (1) to lock the desired cutting head in position. Positive stops are provided at 0 and 45°.

Fig. S

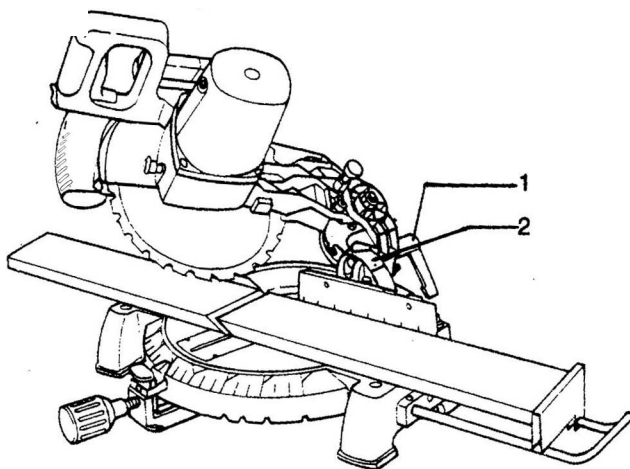

COMPOUND CUT (FIG. T)

A compound cut is the combination of a miter and a bevel cut simultaneously.

1. Loosen the bevel lock handle (1) and position the cutting head at the desired bevel position. Lock the bevel lock handle.
2. Loosen the miter table lock handle (2). Press down the positive stop locking lever (3) and position the table at the desired angle. Release the positive stop locking lever and lock the miter handle.

Fig. T

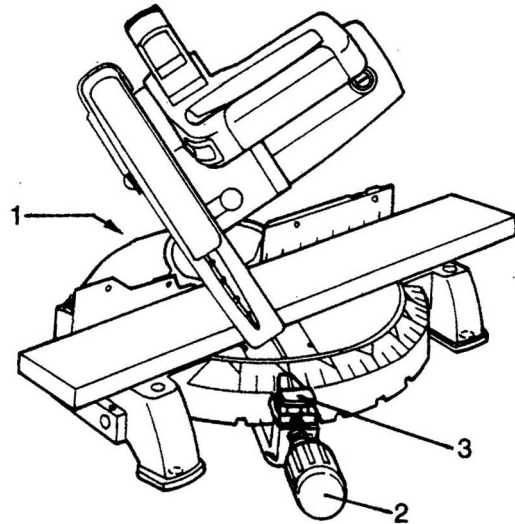

CUTTING BOWED MATERIAL (FIG. U)

A bowed workpiece must be positioned against the fence and secured with a clamping device before cutting. Do not position workpiece incorrectly or try to cut the workpiece without the support of the fence. This will cause the blade to bind and could result in personal injury.

Fig. U

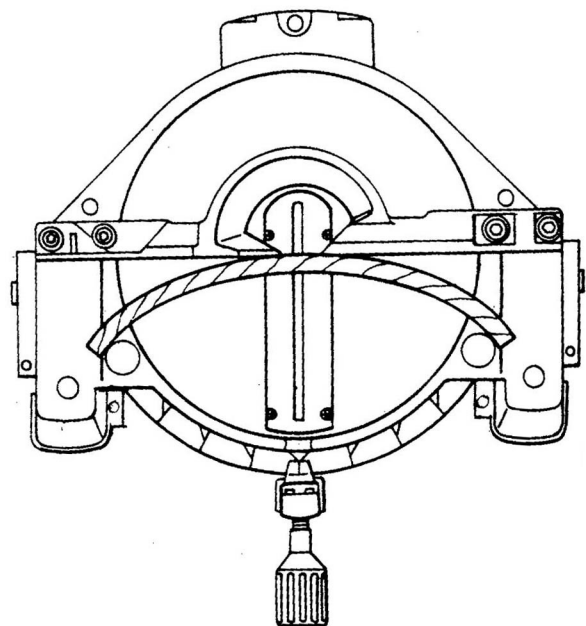

WORKPIECE SUPPORT (FIG. V)

Long pieces need extra support. The support should be placed under the workpiece. Keep your hands out of the "no-hands" zone, positioned 7-1/4" or more away from the blade. The support must let the workpiece lay flat on the worktable during the cutting operation.

NOTE: When mounted on a flat surface, the miter saw table is 3-1/8 inches high.

Fig. V

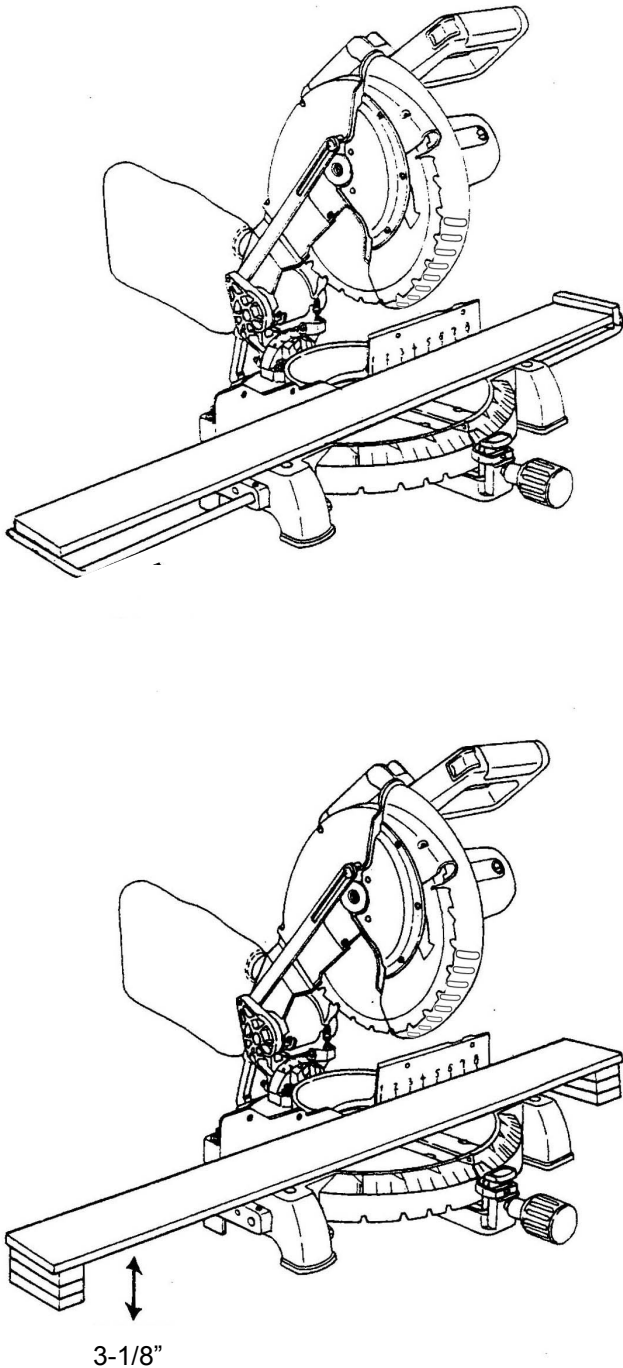

AUXILIARY WOOD FENCE (FIG. W)

When making multiple or repetitive cuts that result in cut-off pieces of one inch or less, it is possible for the saw blade to catch the cut-off piece and throw it out of the saw or into the blade guard and housing, possibly causing damage or injury. To minimize this an auxiliary wood fence can be mounted to your saw.

Holes are provided in the saw fence to attach an auxiliary wood fence. This fence is constructed of straight auxiliary wood approximately 3/4 inch thick by 2-1/2 inches high by 18 inches long.

Attach the wood fence securely and make a full depth cut to make a blade slot.

Check for interference between the wood fence and the lower blade guard. Adjust if necessary.

NOTE: This auxiliary fence is used only with the saw blade in the 0° bevel position (90° to the table). The auxiliary wood fence must be removed when bevel cutting.

Fig. W

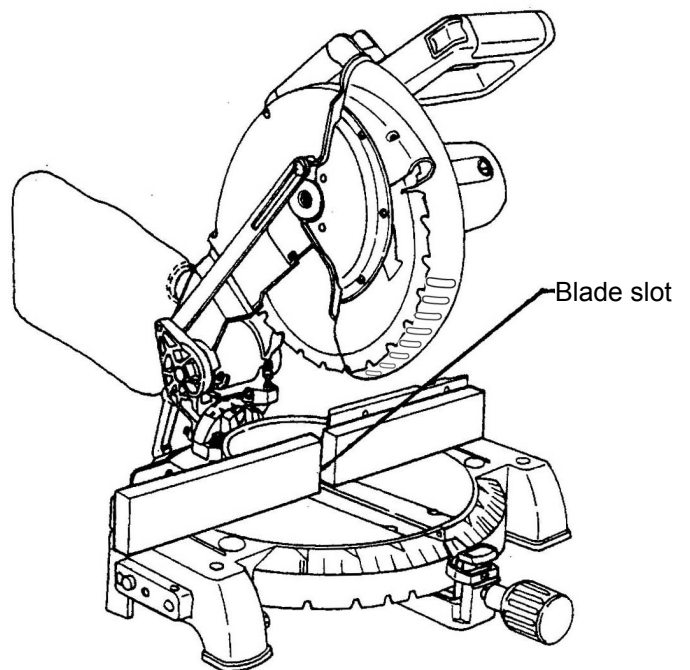

Cutting capacity with auxiliary fence	
Crosscut	3-1/2" x 3-1/12"
Miter 45°R. & L.	3-1/2" x 2"
Bevel 45°L.	2" x 3-1/2"
Compound 45°L., 45°R & L.	2" x 2"

CUTTING A DIMENSIONAL 4X4 WITH ONE CUT (Fig. X)

A dimensional 4x4-in may be cut in half with one cut by attaching an auxiliary wood fence of 3/4 inch thick.

Fig. X

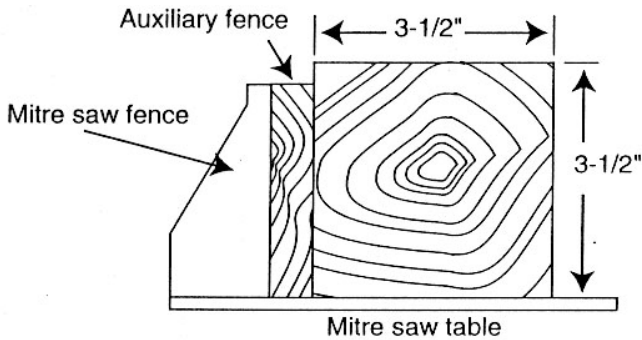

VERTICAL MITER CUTTING (FIG. Y)

To make a miter cut in a 2x4 workpiece (1-5/8" x 3-1/2") in the vertical position on edge a spacer such as the auxiliary wood fence described in the "AUXILIARY WOOD FENCE" section is required.

Fig. Y

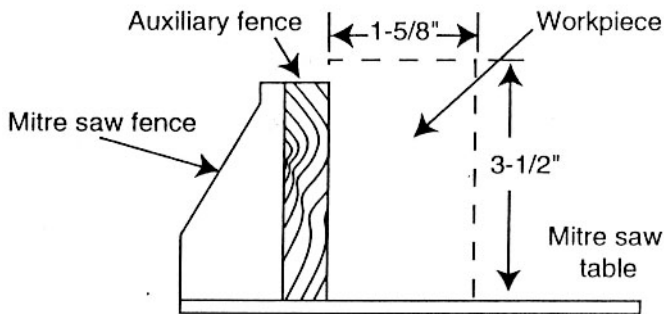

CUTTING BASE MOLDING (FIG. Z)

Base moldings and many other moldings can be cut on a compound mitre saw. The setup of the saw depends on molding characteristics and applications, as shown. Perform practice cuts on scrap material to achieve best results:

1. Always make sure moldings rest firmly against fence and table. Use hold-down or C-clamps, whenever possible, and place tape on the area being clamped to avoid marks.
2. Reduce splintering by taping the cut area prior to making cut. Mark cut line directly on the tape.
3. Splintering typically happens due to wrong blade application and thickness of the material.

Fig. Z

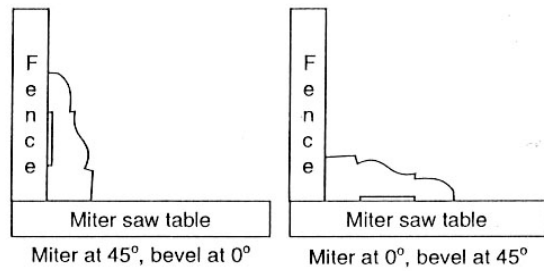

NOTE: Always perform a dry run cut so you can determine if the operation being attempted is possible before power is applied to the saw.

CUTTING CROWN MOLDING (FIG. AA, BB)

Your compound miter saw is suited for the difficult task of cutting crown molding. To fit properly, crown molding must be compound-mitered with extreme accuracy. The two surfaces on a piece of crown molding that fit flat against the ceiling and wall are at angles that, when added together equal exactly 90°.

Most crown molding has a top rear angle (the section that fits flat against the ceiling) of 52° and a bottom rear angle (the section that fits flat against the wall) of 38°.

In order to accurately cut crown molding for a 90° inside or outside corner, lay the molding with its broad back surface flat on the saw table.

When setting the bevel and miter angles for compound miters, remember that the settings are interdependent; changing one changes the other, as well. Also keep in mind that the angles from crown molding are very easy for these angles to shift slightly, all settings should be tested on scrap molding.

Fig. AA

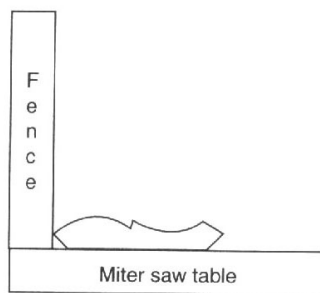
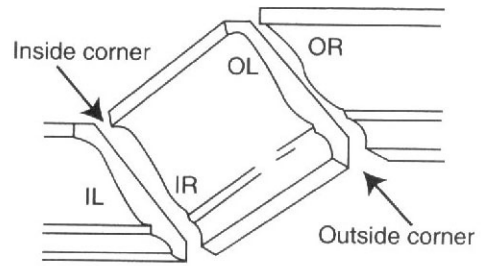

Fig. BB

Settings for standard crown molding lying flat on compound miter saw table



Compound cut crown moldings

Bevel/Miter Settings

KEY	BEVEL SETTING	MITER SETTING	TYPE OF CUT
Inside corner-Left side			
IL	33.9°	31.6° Right	1. Position top of molding against fence. 2. Miter table set at RIGHT 31.6°. 3. LEFT side is finished piece.
Inside corner-Right side			
IR	33.9°	31.6° Left	1. Position bottom of molding against fence. 2. Miter table set at LEFT 31.6°. 3. LEFT side is finished piece.
Outside corner-Left side			
OL	33.9°	31.6° Left	1. Position bottom of molding against fence. 2. Miter table set at LEFT 31.6°. 3. RIGHT side is finished piece.
Outside corner-Right side			
OR	33.9°	31.6° Right	1. Position top of molding against fence. 2. Miter table set at RIGHT 31.6°. 3. RIGHT side is finished piece.

CHANGING THE LASER BATTERIES

CHANGING THE BATTERIES (Fig. CC)

- Unplug your saw.

▲ WARNING

Failure to unplug your saw could result in accidental starting causing possible serious personal injury.

1. Remove the laser guide from the saw.
2. Loosen and remove the two screws (1), then remove the laser guide cover.
3. Remove the three batteries by sliding them out from their mounting braces using a non-conductive device such as a toothpick.
4. Replace the batteries that have a rating of 1.5 volts (Number LR44).
5. Replace the laser guide cover, two screws and laser assembly onto the miter saw.

Note:

When replacing the batteries, the battery cover should be thoroughly cleaned. Use a soft paintbrush or similar device, to remove all sawdust and debris.

FIG. CC

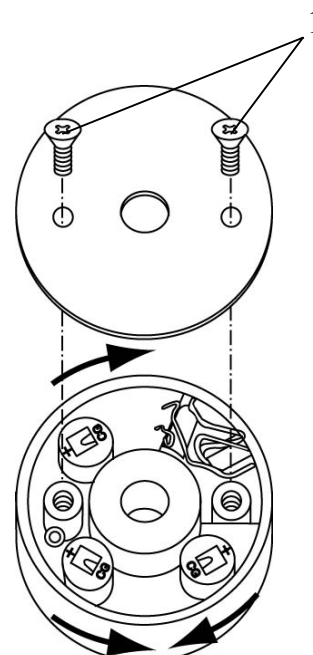

MAINTENANCE

MAINTENANCE

DANGER

Never put lubricants on the blade while it is spinning.

▲ WARNING

To avoid fire or toxic reaction, never use gasoline, naphtha acetone, lacquer thinner or similar highly volatile solvents to clean the miter saw.

▲ WARNING

To avoid injury from unexpected starting or electrical shock, unplug the power cord before working on the saw.

▲ WARNING

For your safety, this saw is double-insulated. To avoid electrical shock, fire or injury, use only parts identical to those identified in the parts list. Reassemble exactly as the original assembly to avoid electrical shock.

REPLACING CARBON BRUSHES (FIG. DD)

The carbon brushes furnished will last approximately 50 hours of running time, or 10,000 ON/OFF cycles. Replace both carbon brushes when either has less than 1/4" length of carbon remaining, or if the spring or wire is damaged or burned. To inspect or replace brushes, first unplug the saw. Then remove the black plastic cap (1) on the side of the motor (2). Remove the cap cautiously, because it is springloaded. Then pull out the brush and replace. Replace for the other side. To reassemble reverse the procedure. The ears on the metal end of the assembly go in the same hole the carbon part fits into. Tighten the cap snugly, but do not overtighten.

NOTE: To reinstall the same brushes, first make sure the brushes go back in the way they came out. This will avoid a break-in period that reduces motor performance and increase wear.

Fig. DD

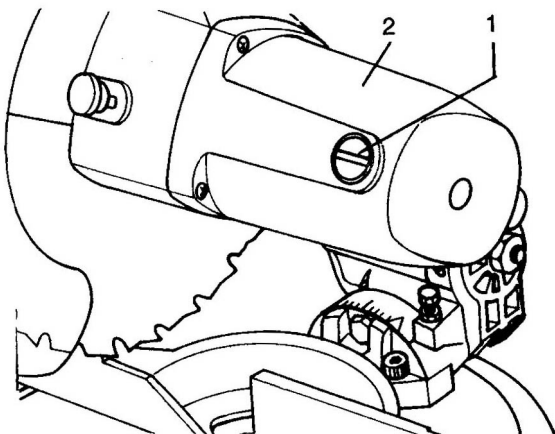

LOWER BLADE GUARD

Do not use the saw without the lower blade guard. The lower blade guard is attached to the saw for your protection. Should the lower guard become damaged, do not use the saw until the damaged guard has been replaced. Develop a regular check to make sure the lower guard is working properly. Clean the lower guard of any dust or buildup with a damp cloth.

AUTION: Do not use solvents on the guard. They could make the plastic "cloudy" and brittle.

▲ WARNING

When cleaning the lower guard, unplug the saw from the power source receptacle to avoid unexpected startup.

SAWDUST

Periodically, sawdust will accumulate under the work table and base. This could cause difficulty in the movement of the worktable when setting up a miter cut. Frequently blow out or vacuum up the sawdust.

▲ WARNING

If blowing sawdust, wear proper eye protection to keep debris from blowing into eyes.

LUBRICATION

All the motor bearings in this tool are lubricated with a sufficient amount of high grade lubricant for the life of the unit under normal operating conditions; therefore, no further lubrication is required.

Lubrication the Following as Required:

Chop pivot: light machine oil or aerosol will penetrate from the ends of the junction points. A qualified service technician can remove the pivot upstop to relieve tension, and the 2 metric set screws holding the shaft, in order to drive the shaft about 3/4" right. Exposed surfaces are lubricated with automotive type oil.

Central pivot of plastic guard: Use light household oil (sewing machine oil) on metal-to-metal or metal-to-plastic guard contact areas as required for smooth, quiet operation. Avoid excessive oil, to which sawdust will cling.

Link: (which actuates the lower guard movement) may be oiled at the rear pivot, greased at ball bearing contact, and oiled where the link actuates the acetyl roller of the lower guard, if the down chop motion is hard to start.

TROUBLESHOOTING GUIDE

▲ WARNING

To avoid injury from accidental starting, always turn switch OFF and unplug the tool before moving, replacing the blade or making adjustments.

Consult your Sears Service Center if for any reason the motor will not run.

TROUBLESHOOTING GUIDE - MOTOR

PROBLEM	PROBLEM CAUSE	SUGGESTED CORRECTIVE ACTION
Brake does not stop blade within 6 seconds.	<ol style="list-style-type: none"> 1. Motor brushes not sealed or lightly sticking. 2. Motor brake overheated from use of defective or wrong size blade or rapid ON/OFF cycling. 3. Arbor bolt loose. 4. Other. 	<ol style="list-style-type: none"> 1. Inspect / clean / replace brushes. See MAINTENANCE section. 2. Use a recommended blade. Let cool down. 3. Retighten arbor bolt. 4. Sears Service Center.
Motor does not start	<ol style="list-style-type: none"> 1. Fuse 2. Brush worn. 3. Other. 	<ol style="list-style-type: none"> 1. Use & check 15-Amp time delay fuse, or circuit breaker. 2. See MAINTENANCE section. 3. Sears Service Center.
Excessive brush spark when switch released.	<ol style="list-style-type: none"> 1. Fuse 2. Brush worn. 3. Other. 	<ol style="list-style-type: none"> 1. Replace Brushes.

TROUBLESHOOTING GUIDE – SAW OPERATION

PROBLEM	PROBLEM CAUSE	SUGGESTED CORRECTIVE ACTION
Blade hits table.	<ol style="list-style-type: none"> 1. Misalignment. 	<ol style="list-style-type: none"> 7. See ADJUSTMENT section. 8. Sears Service Center
Angle of cut not accurate. Can't adjust miter.	<ol style="list-style-type: none"> 1. Miter table locked. 2. Sawdust under table. 	<ol style="list-style-type: none"> 1. Push positive stop locking lever down and rotate table. See OPERATION Section. 2. Vacuum or blow out dust, WEAR EYE PROTECTION.
Cutting arm wobbles.	<ol style="list-style-type: none"> 1. Loose pivot points. 	<ol style="list-style-type: none"> 1. See ADJUSTMENT Section.
Cutting arm won't fully raise, or blade guard won't fully close.	<ol style="list-style-type: none"> 1. Part failure. 2. Pivot spring not replaced properly after service. 3. Sawdust build-up. 	<ol style="list-style-type: none"> 1. Sears Service Center. 2. Sears Service Center. 3. Clean and lubricate moving parts.
Blade binds, jams, burns wood.	<ol style="list-style-type: none"> 1. Improper operation. 2. Dull blade. 3. Improper blade size. 4. Warped blade. 	<ol style="list-style-type: none"> 1. See BASIC SAW OPERATION section. 2. Replace or sharpen blade. 3. Replace with 10" diameter blade. 4. Replace blade.
Saw vibrates or shakes.	<ol style="list-style-type: none"> 1. Saw blade not round. 2. Saw blade damaged. 3. Saw blade loose. 4. Other. 	<ol style="list-style-type: none"> 1. Replace blade. 2. Replace blade. 3. Tighten arbor screw. 4. Sear Service Center.

PARTS

10" MITER SAW PARTS LIST

MODEL: 137.212140

▲ WARNING

When servicing use only CRAFTSMAN replacement parts. Use of any other parts may create a HAZARD or cause product damage.

▲ WARNING

Any attempt to repair or replace electrical parts on this miter saw may create a HAZARD unless repair is done by a qualified service technician. Repair service is available at your nearest Sears Service Center.

Always order by I.D. Number

PARTS LIST FOR SCHEMATIC A

I.D.NO	Description	Size	Qty.	I.D.NO	Description	Size	Qty.
0812	SPRING PLATE		1	0K24	HEX.SOCKET HD.CAP BOLT	M8*1.25-35	2
0818	MITER HANDLE		1	0K2N	HEX.SOCKET HD.CAP BOLT	M8*1.25-25	1
081A	PLASTIC SLEEVE		1	0K2S	HEX.SOCKET HD.CAP BOLT	M8*1.25-20	3
081D	NEEDLE POINTER		1	0K3J	CR.RE.PAN HD.TAPPING SCREW	M4*0.7-16	3
081G	FOLLOWER PLATE		5	0K56	CR.RE.COUNT HD.SCREW	M5*0.8-12	1
081J	TABLE INSERT		1	0K5C	CR.RE.COUNT HD.SCREW	M6*1.0-16	1
081K	MITER SCALE		1	0K7Z	CR.RE.TRUSS HD.ROUND NECK SCREW	M6*1.0-14	2
081U	SUPPORT		1	0K9X	DRIVE SCREW	Φ2.3-5	2
0821	BEVEL SCALE		1	0KBD	CR.RE.PAN HD.TAPPING SCREW	M4*18-25	6
0824	PIVOT SHAFT		1	0KCX	CR.RE.PAN SCREW	M5*0.8-10	5
0826	NEEDLE POINTER		1	0KD7	CR.RE.PAN HD.TAPPING SCREW	M4*0.7-10	4
0828	ROTATION SLIDE PLATE		1	0KDM	CR.RE.PAN HD.SCREW	M5*0.8-20	2
0829	ANGLE REGULATOR		1	0KDN	CR.RE.PAN HD.SCREW	M5*0.8-25	1
0831	SHAFT SLEEVE		1	0KDR	CR.RE.PAN HD.SCREW	M5*0.8-10	2
083R	TRIGGER		1	0KDT	CR.RE.PAN HD.SCREW	M6*1.0-8	2
083Y	COMPRESSION SPRING		1	0KE0	CR.RE.PAN HD.SCREW	M6*1.0-40	2
083Z	CORD CLAMP		1	0KMS	HEX.NUT	M6*1.0 T=5	1
084W	LABEL		1	0KQX	HEX.NUT	M6*1.0 T=6	1
0BAG	BLADE		1	0KQX	LOCK NUT	M6*1.0 T=6	1
0CES	COMPRESSION SPRING		1	0KQZ	LOCK NUT	M10*1.5 T=10	1
0CKS	WIRE SPRING		1	0KR0	LOCK NUT	M12*1.75 T=12	1
0CM2	SAFETY CLAMP		1	0KUX	TERMTNAL		1
0CQH	BEVEL LOCK HANDLE ASS'Y		1	0LU2	LIMIT SWITCH		1
0CV5	DUST BAG ASS'Y		1	0QQ1	GUARD-CORD		1
0D7W	LOCKING LATCH		1	0S1N	ARM-MITER		1
0D7X	SHAFT		1	0S1P	TABLE		1
0D7Z	LOCKING LATCH KNOB		1	0S1S	COLLAR		1
0D87	TORSION SPRING		1	0S1T	HOUSING ASSEMBLY		1
0D99	SHIM		1	0S2B	CR.RE.PAN HD.TAPPING SCREW	M6*1.0-25	2
0D9B	ANCHOR BLOCK		1	0STZ	LABEL		1
0D9R	CAUTION LABEL		1	0V8C	POWER CABLE		1
0D9S	CHIP PLATE		1	0V8M	FENCE		1
0D9T	RUBBER PAD		1	0V9J	MOTOR		1
0DHT	SPRING		1	0XK9	BUTTON SWITCH		1
0DTZ	ARBOR COLLAR		1	0XKA	SEGMENT HADELE		1
0DVJ	BLADE WRENCH		1	0XQ5	HANDLE COVER		1
0DWU	STOP BLOCK		1	0XQ6	HANDLE		1
0DWW	EXTENTION WING		2	20Z0	LEVER		1
0J4J	FLAT WASHER	Φ10*20-2	1	21K2	BASE		1
0J4R	FLAT WASHER	Φ10*20-3	1	21K3	WING BOLT	M6*1.0-20	1
0J7R	FLAT WASHER	1/2*1-3/64	1	23E0	BRACING PLATE		1
0JMM	O-RING		1	25NZ	ARBOR LASER ASS'Y		1
0JPE	HEX.HD.BOLT	M6*1.0-20	1	25Q5	PC-GUARD		1
0JQT	HEX.HD.BOLT	M10*1.5-75	1	26Q0	TRADE-MARK LABEL		1
0JUK	HEX.SOC.HD.CAP BOLT	M6*1.0-16	1	26WS	MOTOR LABEL		1
0JVY	HEX.SOC.HD.CAP BOLT	M6*1.0-16	2	279L	WARNING LABEL		1
0JZD	HEX.SOC.SET SCREW	M5*0.8-10	1				
0JZF	HEX.SOC.SET SCREW	M6*1.0-10	2				
0JZN	HEX WASHER HD BOLT	M8*1.25-20	1				
0K0W	HEX.HD.SCREW AND WASHER	M6*1.0-25	2				
				26RV	INSTRUCTION MANUAL		1

**10" COMPOUND MITER SAW
SCHEMATIC A**

MODEL: 137.212140

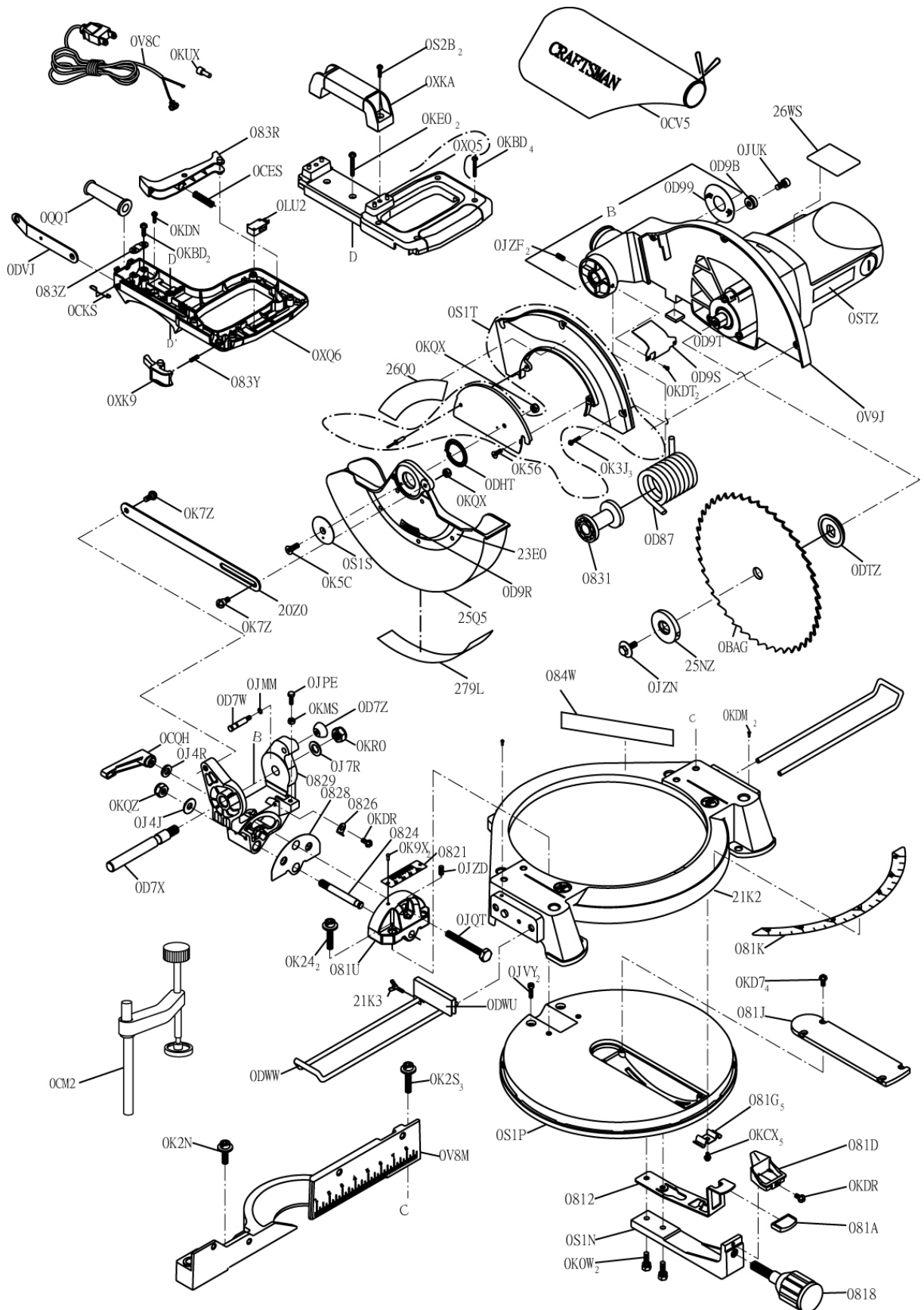

PARTS LIST FOR SCHEMATIC B MOTOR

I.D. NO.	DESCRIPTION	SIZE	QTY
0HV5	BALL BEARING	6204LLU	1
0HX9	NEEDLE BEARING	HK-1010	1
0JEB	C-RING	A-14	1
0JEG	C-RING	A-20	1
0JG7	PARALLEL KEY		1
0JX2	HEX.SOC SET SCREW	M5*0.8-6	2
0K3A	CR.RE.PAN HD.TAPPING SCREW&WASHER	M5*0.8-30	4
0K7G	CR.RE.ROUND HD. WASHER SCREW	M5*0.8-10	3
0KLA	PLASTIC SCREW	M5*0.8-6	2
0Q9K	FLOW GUIDE		1
0QGR	COMPRESSION SPRING		1
0QM4	ARBOR SHAFT		1
0QM7	BEARING COVER		1
0QM8	HELIX GEAR		1
0QME	BRACKET STOP		1
0QMK	PLASTIC CAP		1
0QMR	ARMATURE ASS'Y		1
0QMX	FIELD ASS'Y		1
0QMY	WIRE PROTECTOR		1
0QMZ	MOTOR HOUSING		1
0QQS	BRUSH HOLDER ASS'Y		2
0QQT	BRUSH ASS'Y		2
0QR0	BRUSH COVER		2
0QR2	BEARING BUSHING		1
1102	SPRING PIN		1
110A	CR.RE.PAN HD.TAPPING SCREW&WASHER	M5*12-55	2
144L	LEAD WIRE ASS'Y		1
148B	UPPER ARM		1

MOTOR

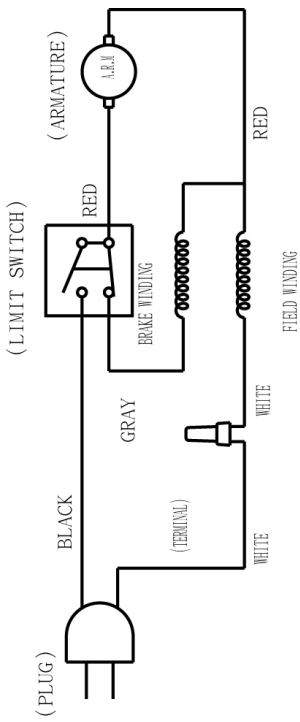

Wiring diagram

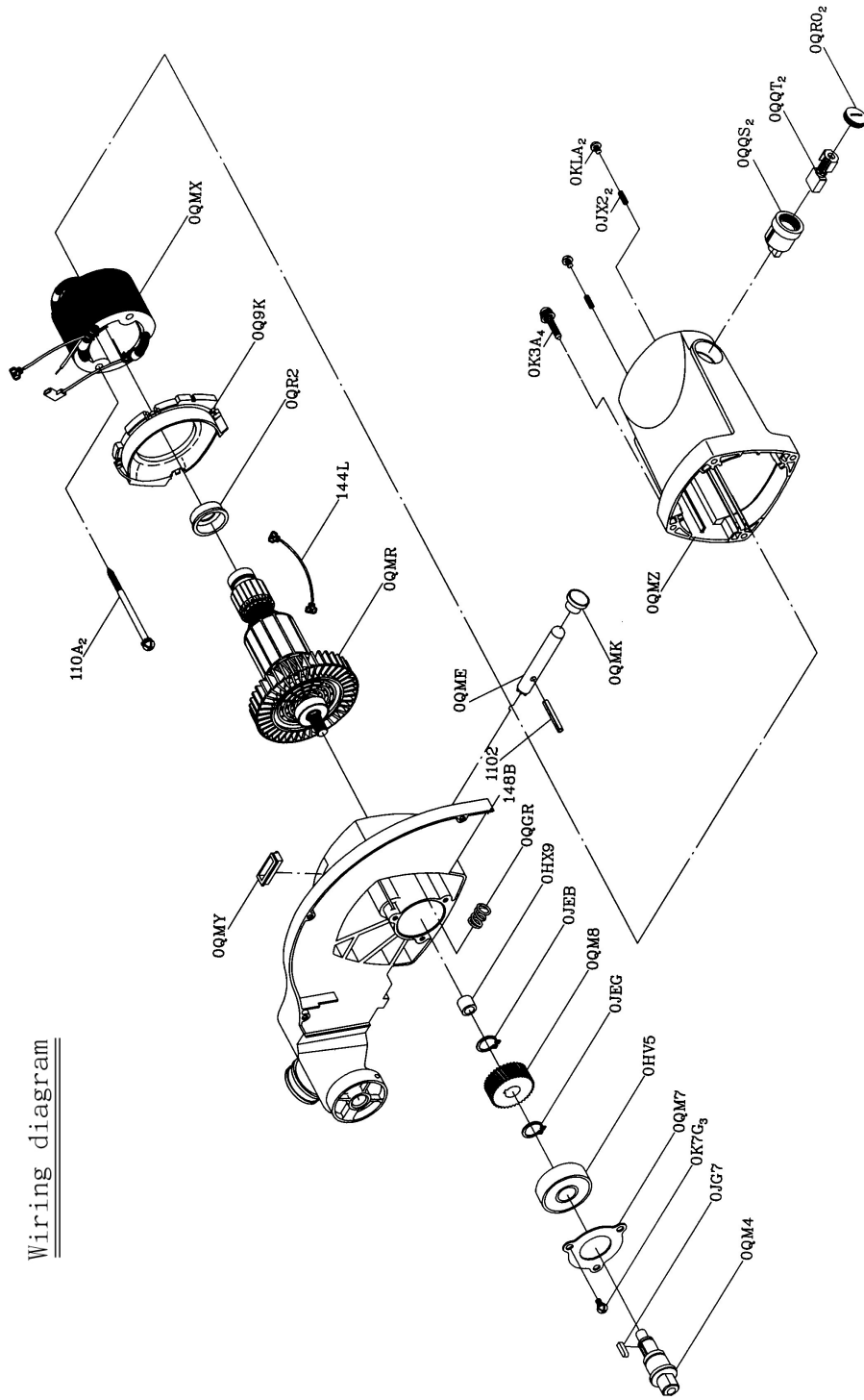

Get it fixed, at your home or ours!

Your Home

For repair – **in your home** – of **all** major brand appliances, lawn and garden equipment, or heating and cooling systems, **no matter who made it, no matter who sold it!**

For the replacement parts, accessories and Operator's Manuals that you need to do-it-yourself.

For Sears professional installation of home appliances and items like garage door openers and water heaters.

1-800-4-MY-HOME® (1-800-469-4663)

Call anytime, day or night (U.S.A. and Canada)

www.sears.com www.sears.ca

Our Home

For repair of carry-in items like vacuums, lawn equipment, and electronics, call or go on-line for the location of your nearest **Sears Parts & Repair Center.**

1-800-488-1222

Call anytime, day or night (U.S.A. only)

www.sears.com

To purchase a protection agreement on a product serviced by Sears:

1-800-827-6655 (U.S.A.)

1-800-361-6665 (Canada)

Para pedir servicio de reparación a domicilio, y para ordenar piezas:

1-888-SU-HOGARSM

(1-888-784-6427)

Au Canada pour service en français:

1-800-LE-FOYER^{MC}

(1-800-533-6937)

www.sears.ca

SEARS

® Registered Trademark / TM Trademark / SM Service Mark of Sears, Roebuck and Co.

® Marca Registrada / TM Marca de Fábrica / SM Marca de Servicio de Sears, Roebuck and Co.

^{MC} Marque de commerce / ^{MD} Marque déposée de Sears, Roebuck and Co.

© Sears, Roebuck and Co.